

INSTALLATION, OPERATION AND SERVICE MANUAL

FREIGHTLIFT

Model FLM

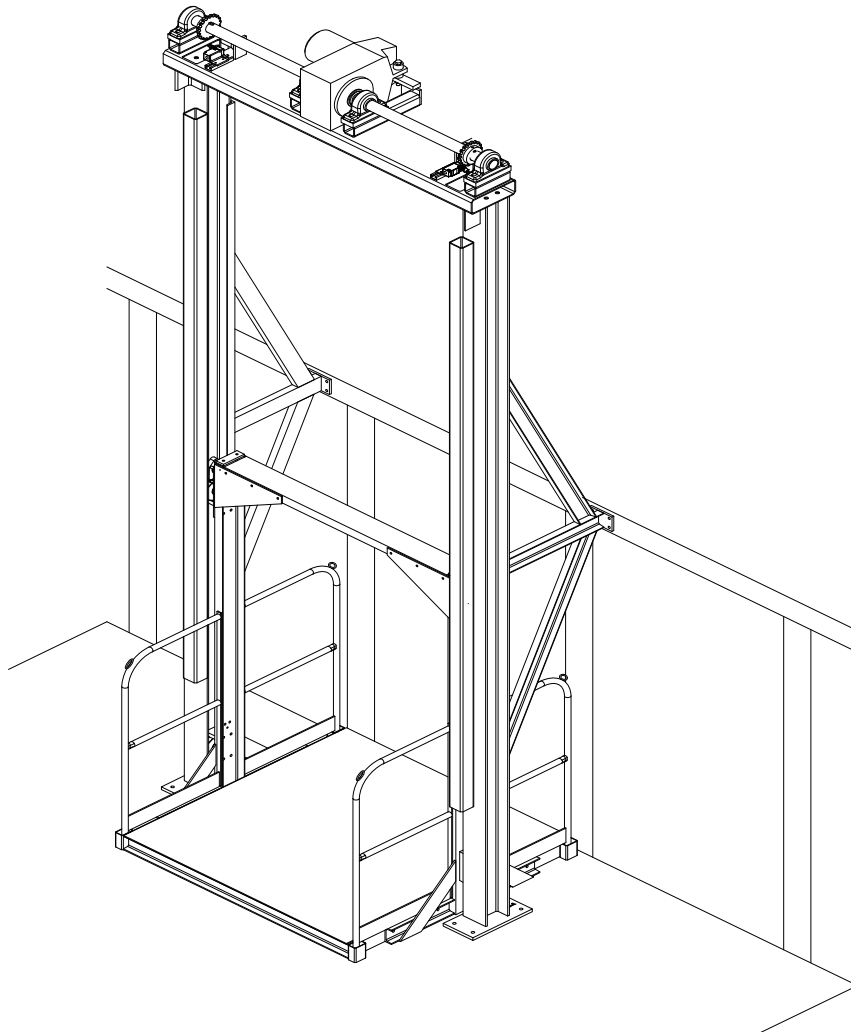

Autoquip[®]

P.O. Box 1058 • 1058 West Industrial Avenue • Guthrie, OK 73044-1058 • 888-811-9876 •
405-282-5200 • FAX: 405-282-3302 • www.autoquip.com

830FLM

Version 3.3
Dec. 2010

TABLE OF CONTENTS

Introduction & Company Contact Information	3
Inspection & Identification of Parts	4
Responsibility of Owners/Users	5
Safety Signal Words	6
Safety Practices	7
Safety Features	12
Label Identification	15
Specifications	18
Blocking Instructions	19
Installer Guidelines & Responsibilities	22
Installation Instructions	27
Operating Instructions	77
Routine Maintenance	82
General Maintenance	85
Replacement Parts List	87
Troubleshooting Analysis	88
Glossary of Terms	91
Appendix – Inspection Checklist	93
Warranty	96

Please record the following information and refer to it when calling your dealer or Autoquip.

Model Number: _____ **Serial Number:** _____

Installation Date ____ / ____ / ____

INTRODUCTION

CODE REQUIREMENTS

VRCs are NOT elevators. This lift is designed for the transfer of material only from one level to another. Absolutely NO RIDERS! VRCs have their own national safety code (ANSI/ASME B20.1) and are specifically exempt from the National Elevator Code.

Some states require special components and have specific guidelines regarding how the equipment must be installed, inspected, and tested. The owner is ultimately responsible for understanding these requirements for the specific job location, and Autoquip will incorporate any special requirements into the order as requested and approved by the customer.

Call Autoquip Corporation at (405) 282-5200 or 1-888-811-9876 with any questions you may have concerning VRC code requirements.

IMPORTANT

Autoquip Corporation has designed and manufactured the FREIGHTLIFT to safely and efficiently move materials between multiple floors or levels. It has been built to provide many years of dependable service.

INSTALLERS - Proper installation of this equipment is vital to both the efficiency of the unit and the ultimate satisfaction of the end user. **It is vital for the installers to read and understand this manual!** These instructions have been prepared and organized to assist the installers and it is important for these individuals to carefully follow the steps in the order they are presented!

OPERATORS - Please read and understand this manual prior to operation of this Freightlift. Failure to do so could lead to property damage and/or serious personal injury.

Situations may arise which are not covered in this manual. **If you have questions, please call *Autoquip* Customer Service at (405) 282-5200 or 1-888-811-9876.**

NOTE: Unless otherwise stated, mechanical installation does not include unloading, permits, seismic calculations, or extensive acceptance testing. The requirements of each contract should be carefully reviewed for possible conflicts of interpretation.

PLANNED MAINTENANCE PROGRAM

A local *Autoquip* representative provides a Planned Maintenance Program (PMP) for this equipment using qualified and experienced personnel. **Call a local representative or *Autoquip Corporation* at 1-888-811-9876 or 405-282-5200 for more information.**

INSPECTION & IDENTIFICATION

Your FREIGHTLIFT arrives packaged as follows: The two (2) masts and platform (either 1-piece or 2-piece if spliced) come on shipping skid(s), you also receive parts skids / crate(s) which normally contain the following items:

- A. One Steel Tube Drive Base with Gear Motor, Shaft & Bearings
- B. Two Carriage Upright Assemblies
- C. Four Platform Carriage Side Guards (Handrails)
- D. (2) Upper Wheel Assemblies; (2) Lower Wheel Guide Assemblies
- E. Two Tension Roller Assemblies
- F. Two Equal Lengths of Lifting Chain
- G. Two Counterweights & Lifting Chain Kits with Chain Adaptors, Pins, etc.
- H. (1) 6" Overhead Channel
- I. One Installation Angle (with bolts on each end)
- J. Upper level bracing, includes brace plates & channels (see Record Dwg)
- K. (1) Counterweight Sensing Switch Kit; (2) Slack Chain Sensing Switch Kits (for lifting chains), and Level/Over-travel Limit Switch Kits (quantity depends on number of levels).
- L. Miscellaneous hardware, manuals, signs, extra structural supports etc. (depends on order – consult Packing List)

NOTE: The “Bill of Lading” will state the number of pieces shipped. TWO ITEMS MAY BE BANDED TOGETHER AND COUNT AS ONE PIECE.

Upon receipt of the shipment, check for exposed damage or shortages and make note of it on the trucking company Bill of Lading or the Shipping Papers. Reports of concealed damage to items contained in crates must be reported within 48 hours. DO NOT destroy the crating while opening it to inspect the contents. If damage is suspected or found, report it directly to the carrier. DO NOT contact *Autoquip Corporation*!! All shipments are FOB from the Autoquip plant. **Any claims for damage must be filed with the carrier. Any parts shipped from *Autoquip* that are intended to replace damaged or lost items will be invoiced to the ordering party.**

Assuming no damage has occurred to the crate, check the components against the packing list. This will provide assurance that every item shipped has been received. Everything needed for the installation should be available. If not, report any shortages to *Autoquip Corporation* within 10 days. (*Autoquip* is not responsible for parts lost, stolen or damaged during transportation, storage, installation, or during any other circumstances or conditions that may be beyond Autoquip's control.)

RESPONSIBILITY OF OWNERS/USERS

CODE COMPLIANCE

Ultimate responsibility for gaining state and local code approval is the responsibility of the buyer of the VRC. Please acquaint yourself with the permitting and/or licensing expenses and requirements of the local regulatory agencies in the installation area.

INSPECTION & MAINTENANCE

The lift shall be inspected & maintained in proper working order in accordance with this manual and with other applicable safe operating practices.

REMOVAL FROM SERVICE

Any lift in service which is not in safe operating condition such as, but not limited to, excessive leakage, missing rollers, pins, or fasteners, any bent or cracked structural members, cut or frayed electric or hydraulic lines, damaged or malfunctioning controls or safety devices, etc. shall be removed from service until repaired to original manufacturer's standards.

REPAIRS

All repairs shall be made by qualified personnel in conformance with Autoquip's instructions.

OPERATORS

Only trained personnel and authorized personnel shall be permitted to operate the lift.

BEFORE OPERATION

Before using the lift, the operator shall have:

- Read and/or had explained, and understood, the manufacturer's operating instructions and safety rules.
- Inspected the lift for proper operation and condition. Any suspect item shall be carefully examined and a determination made by a qualified person as to whether it constitutes a hazard. All items not in conformance with Autoquip's specification shall be corrected before further use of the lift.

DURING OPERATION

The lift shall only be used in accordance with this Manual.

- Do not overload the lift.
- Do not allow any portion of the load to overhang the perimeter of the carriage.
- Ensure that all safety devices are operational and in place.

MODIFICATIONS OR ALTERATIONS

Modifications or alterations to industrial lifting equipment shall be made only with written permission of Autoquip. Autoquip does not foresee and does not anticipate unauthorized modifications, and these changes or alterations are grounds for voiding all warranties.

SAFETY SIGNAL WORDS

SAFETY ALERTS (Required Reading!)

The following SAFETY ALERTS are intended to create awareness of owners, operators, and maintenance personnel of the potential safety hazards and the steps that must be taken to avoid accidents. These same alerts are inserted throughout this manual to identify specific hazards that may endanger uninformed personnel. Identification of every conceivable hazardous situation is impossible. Therefore, all personnel have the responsibility to diligently exercise safe practices whenever exposed to this equipment.



DANGER!

Identifies a hazardous situation which, if not avoided, will result in death or severe personal injury.



WARNING!

Identifies a hazardous situation which, if not avoided, could result in death or serious personal injury.



CAUTION!

Identifies a hazardous situation which, if not avoided, may result in minor or moderate personal injury.

NOTICE

Identifies a situation or practice not related to personal injury.

SAFETY PRACTICES



DANGER!

High voltage! May cause personal injury or death. Repairs should only be performed by a qualified service/control technician.



DANGER!

Never go under a platform! To avoid personal injury or death, always be sure the load has been removed from the platform and that it has been adequately blocked from underneath. See “Blocking Instructions” section.



DANGER!

Qualified personnel only!! Only qualified service personnel should perform procedures labeled as “dangerous”.



DANGER!

Be sure of equipment stability! To avoid personal injury or death, check for stability. If the supports seem unstable, do not operate! Contact *Autoquip* immediately at 888-811-9876.



DANGER!

Turn off power! To avoid personal injury or death, be sure the power is off and is locked out at the primary power disconnect switch per OSHA Lock-Out, Tag-Out procedures.

SAFETY PRACTICES



DANGER!

Practice field safety procedures! To avoid personal injury or death, utilize all applicable precautions for steel erection and equipment assembly in addition to OSHA Lock-Out, Tag-Out procedures.



DANGER!

Support all beams and components! Illustrations in this manual may show them unsupported. This is done in order to make the equipment and its installation clearly understood. Be sure to properly secure all lift beams and components on the actual unit.



DANGER!

Secure platform and chains! Do not remove or disconnect the motor or brake unless the platform and chains have been secured. See “Blocking Instructions” section.



DANGER!

Secure platform when attempting to free a jammed carriage! Do not walk out onto carriage or attempt to access or remove a jammed load unless the carriage has been secured to prevent unexpected movement or uncontrolled descent. (See “Blocking Instructions” section)



WARNING!

No riders! The FREIGHTLIFT is provided for the sole purpose of transporting goods between floor elevations. At no time should it be used to transport personnel.

SAFETY PRACTICES



WARNING!

Slack chains require factory help! Do not attempt to repair slack chain conditions alone! Always contact the local representative or call the *Autoquip* Service Department at 888-811-9876.



WARNING!

Never run the unit with the gates or doors open! Do not operate unit with doors open or with the interlocks “defeated” (bypassed)! Serious injury or death could result.



WARNING!

Never go under platform carriage! Use a long-handled broom or similar implement to remove debris that may accumulate.



WARNING!

Secure unit before making static inspections! Make sure the platform is fully lowered and the power is turned off (disconnected at the safety disconnect switch) before performing static inspections. Place signs at all gates, doors, controls, etc. indicating the system is temporarily out of service for routine maintenance per OSHA Lock-Out, Tag-Out procedures.



WARNING!

Close all gates when not in use! Never leave the FREIGHTLIFT unattended with gates left open.

SAFETY PRACTICES



WARNING!

Never operate unit when parts are broken or damaged! Do not operate this equipment when non-factory approved or damaged parts are in use! Contact the local FREIGHTLIFT Service Representative to rectify all such situations.



WARNING!

Use proper chain or chain master links! Never use chain or chain master links which are not properly rated for the intended use.



WARNING!

Do not over travel! Over travel limit switches must be in place and operating as intended before operating the lift.



WARNING!

Do not weld on the guide flanges of the masts! Interfering with the free travel of the wheel guides could cause permanent damage to the lift and prevent safety devices from operating as intended.

SAFETY PRACTICES



CAUTION!

Chains must be seated before raising lift! Be sure the chains are seated in the sprockets on top of the mast prior to raising the lift.



CAUTION!

Do not run carriage until limits are set! If the electrical is not complete, do not run the carriage all the way to the top or all the way back down until the limits are set.

NOTICE

Do not run the gear reducer when it is dry! Running the system in a dry condition can result in serious damage to the equipment.

SAFETY FEATURES

There are several primary active safety features and devices to help protect personnel, property, and the equipment.

LOCKING CAMS (Reference Figure 19)

Each chain is terminated at the platform carriage in a clevis, which is attached to a tension spring loaded steel safety cam. This safety cam pivots on a high strength steel pin which is chrome plated. The safety cam has serrated teeth cut into one of its faces that are adjacent to the guide beam flange.

Should the chain become slack, the spring tension would cause the serrated teeth of the safety cam to engage the guide beam. The teeth bite into the guide beam and a wedging effect takes place between the safety cam and the guide beam. The result is a positive halt to downward movement.

The only way to release the safety cam is to correct the malfunction that caused the slack chain and exert upward tension on the chain through the chain drive. Either of the two cams will support the loaded platform carriage at any point in the vertical travel.



WARNING!

Slack chains require factory help! Do not attempt to repair slack chain conditions alone! Always contact the local representative or call the Autoquip Service Department.

SLACK CHAIN SENSORS (Reference Figures 33)

The slack chain sensors are located on the drive base. The sensors are made up of a mechanical spring tensioner with a nylon roller and an electrical sensing switch. The lifting chains run over the sprockets on the main shaft, beside the slack chain sensors, and then to the carriage. The carriage holds the chains in constant tension. The sensing switch arm is adjusted to hold the sensing switch contacts closed as the tensioner roller is running against the taut chain. Should a chain become slack or broken, the spring tensioner would rotate and activate the sensing switch arm to open its normally-closed electrical contacts. This would break electrical power to the drive motor and cease movement of the carriage. The lift will not operate until each slack chain sensor is restored to its correct operating condition. There is one (1) slack chain sensor per lifting chain.

CARRIAGE OVER-TRAVEL LIMIT SWITCH (Reference Figure 30)

A redundant, over-travel limit switch is provided to be field located and installed beneath the drive base in order to stop the motor should the carriage not stop at the upper level limit switch location (due to faulty wiring, out-of-adjustment or damaged limit switch arm, etc.). Making of this switch would break the electrical circuits, shut off the motor, and cease movement of the carriage. The carriage will not move until the over-travel limit device is restored to its correct operating condition.

SAFETY FEATURES

ELECTRICAL CURRENT SENSOR (ECS) (Reference Figure 35)

The ECS with trip relay is used to prevent overloading of the FREIGHTLIFT by sensing an increase in the motor amps drawn should the carriage be overloaded or jammed. The increase of motor amps will kick the relay out and shut off the motor circuit. This condition will continue until the carriage overload or jam condition is removed/resolved.

CONTROL TRANSFORMER SECONDARY FUSE

This fuse is located in the control enclosure. It is attached to the electrical control transformer and protects the 115 volt control circuit from damage should a fault occur which would result in excessive electric current flow. Should the fuse activate (blow) it will prevent the operation of the FREIGHTLIFT in either direction.



DANGER!

Turn off power! To avoid personal injury or death, be sure the power is off and is locked out at the primary power disconnect switch per OSHA Lock-Out, Tag-Out procedures.

SAFETY INTERLOCKS & STATUS SWITCHES – GATES OR DOORS **(where applicable)**

There are electro/mechanical devices that prevent operation of the FREIGHTLIFT when the gates or doors at any floor level are open. They also prevent the gates or doors from being opened at any level unless the platform carriage is in place at that floor level.



WARNING!

**Close all gates when not in use! Never leave the FREIGHTLIFT unattended with gates left open.
Never run the unit with the gates or doors open! Do not operate unit with doors open or with the interlocks “defeated” (bypassed). Serious injury or death could result.**

COUNTERWEIGHT SENSING SWITCH (Reference Figure 34)

This switch is located on the top of one (1) counterweight tube as a redundant sensing device in the event the slack chain sensors are not performing as designed and the lift motor continues to run in an attempt to lower a jammed carriage. If the counterweights attempt to be pulled from their tubes, this switch will activate and will cut off electrical power to the motor.

SAFETY FEATURES

PERSONNEL GUARDS

Depending on the application, one or more of the following personnel protection features is included in the design of this equipment (different states may vary on the exact design and orientation of these features – IT IS IMPORTANT TO BECOME FAMILIAR WHICH THE SPECIFIC CODE REQUIREMENTS OF YOUR STATE):

- **GATES & ENCLOSURES**: Required per ASME B20.1 to protect personnel from inadvertent physical contact with a moving lift & moving load at all lift landings.
- **CARRIAGE RAILINGS & SNAP CHAINS**: Required per ASME B20.1 to protect personnel whenever personnel walk onto the lift carriage when in the raised position. Railings or side guards protect non-operating sides, snap chains protect operating sides.
- **CARRIAGE BACK-STOP PANELS**: Additional safety feature recommended at all upper levels to provide additional fixed guarding 2” (max.) away from & across all unused, operating sides of the lift (typical with non-shaftway “Z” & 90 degree load patterns).

NOTE: If the personnel guards are not purchased from Autoquip it is the responsibility of the Owner to make sure that the personnel guards are in compliance with the requirements set forth in ASME B20.1.

SHAFTWAY DOOR BARRIER BARS (where applicable)

Shaftway door barrier bars are designed to provide a secondary means of personnel protection at the uppermost level landing of an FLM shaftway installation. When the carriage is not present at the upper level, the two barrier bars rest in permanent brackets attached to both sides of the door frame on the outside (shaft side) of the upper level door. The barrier bars form rigid barriers at approximately 24” and 48” above floor level. In the unlikely event that the upper level door is able to be opened when the carriage is not at the upper landing, the bars provide an additional means of personnel protection against stepping or backing into the shaftway where the carriage could be assumed to be present.

When properly installed, the barrier bars are lifted up and along their tracks by the carriage as it approaches the upper landing until it is completely above the load height as the lift stops. As the lift moves to the lower level, it carries the bars back to their stationary brackets attached to the outside of the door.



WARNING!

Shaftway door barrier bars are not intended to be used as a primary means of personnel protection. It is the responsibility of the operator to ensure that all gate/door interlocks have been installed and are functioning properly. Serious injury or death could result if upper level gates/doors can be opened when the lift is not present at that level.

LABEL IDENTIFICATION

Field-locate & apply one “WARNING – Do Not Tamper” label adjacent to (within 6”-12”) each sensing device (limit switches, door status switches, door interlocks, etc.) in a location that is visible to the operator.

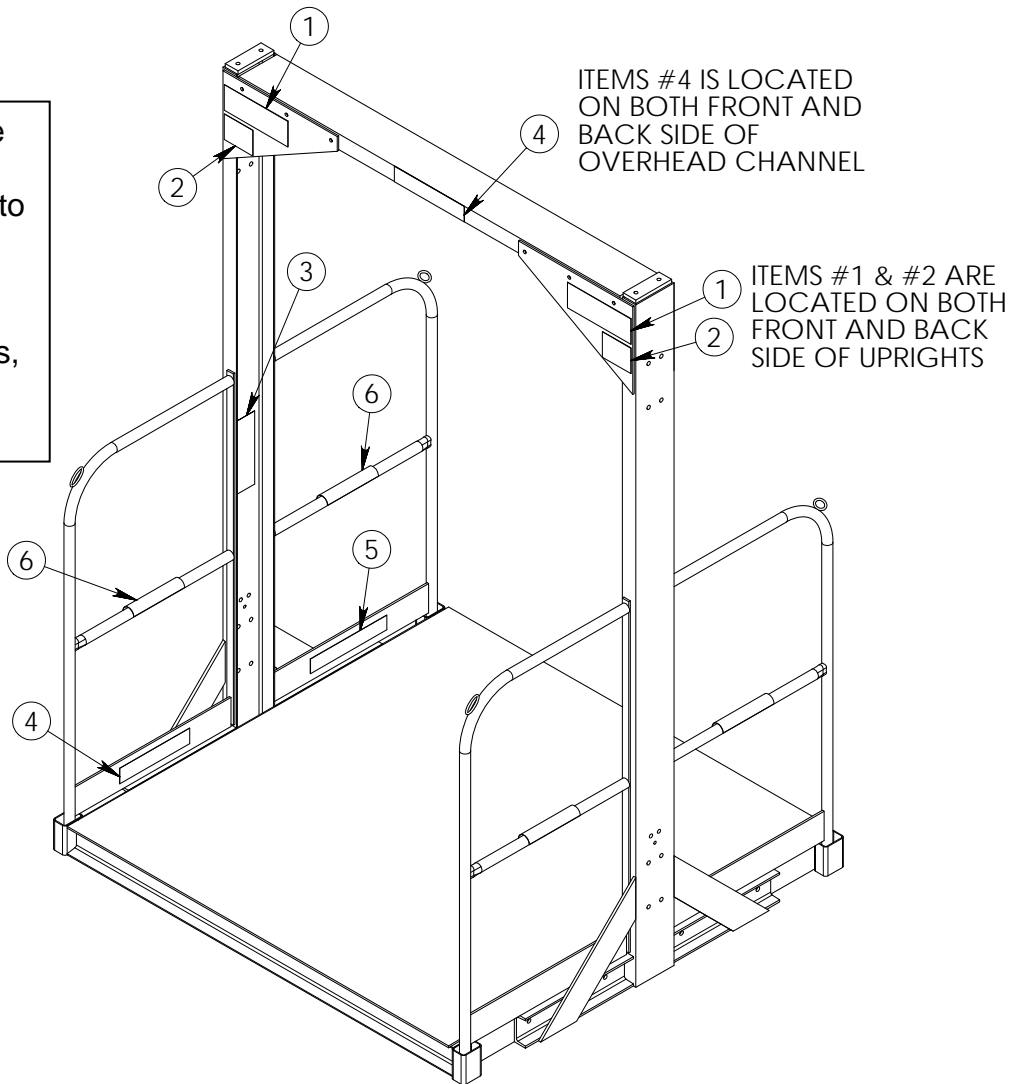

Figure 1 Label Placement Diagram for FLM

Item #	Qty.	Description	Part No.
1	4	Warning – No Riders	36404093
2	4	Freightlift by Autoquip Logo	36402680
3	1	Serial Number Nameplate	36401560
4	4	Capacity	36401586
6	varies	Warning – Personnel Guarding	36403720
7	varies	Warning – No Riders (located on ea. P/B)	36405705
8	1	Warning – Do Not Disassemble Motor/Brake	36405110

LABEL IDENTIFICATION

Note: Labels shown here are not actual size.



Figure 2 Label 36404093



Figure 3 Label 36402680

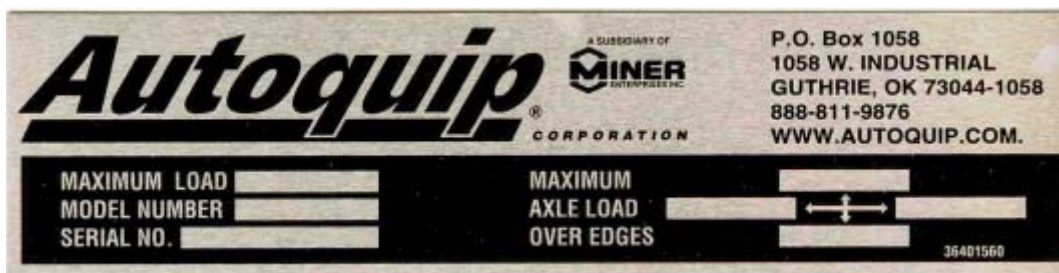

Figure 4 Label 36401560

LABEL IDENTIFICATION



Figure 5 Label 36401586



Figure 7 Label 36403720



Figure 8 Label 36405705



Figure 9 Label 36405110

GENERAL SPECIFICATIONS

FLM Standard Models

Model	Max Travel	Capacity (pounds)	Platform (Min) W x L	Platform (Max) W x L	HP** (Min)	Standard Speed (fpm)
FLM-1	100'	1000	4' x 3'	10' x 12'	3	30
FLM-2	100'	2000	4' x 3'	10' x 12'	3	30
FLM-3	100'	3000	4' x 3'	10' x 12'	5	30
FLM-4	100'	4000	4' x 3'	10' x 12'	5	30
FLM-5	100'	5000	4' x 3'	10' x 12'	7.5	30
FLM-6	100'	6000	4' x 3'	10' x 12'	7.5	30

** Actual HP varies depending on the total hung weight of the loaded carriage and the particular speed required for the application.

DO NOT EXCEED RATED CAPACITY OF THE LIFT. Loading the lift beyond its rated capacity is unsafe, will shorten the operational life of the lift, and will void its warranty.



WARNING!

Do not make modifications to the lift without authorization from the manufacturer! Unauthorized and unforeseen carriage, lift structure, drive base or support bracing attachments added in the field could create an unsafe operating condition which could result in severe personal injury or death.

LIFT DUTY

Autoquip standard lift designs as described in the specifications are designed to “cycle” (one complete “up” and one complete “down” lift operation) no more frequently than every two minutes – or approximately 10,000 times (cycles) per year. This is considered “normal” duty.

It is the responsibility of the user to notify Autoquip whenever a specific application is likely to demand “above normal” duty from the lift - in excess of 10,000 cycles per year. Above normal duty typically requires supplemental design features to enhance the serviceable life of the lift & to avoid loss of warranty.

BLOCKING INSTRUCTIONS



WARNING !

Only authorized personnel should perform inspection or maintenance and service procedures. Unauthorized personnel attempting these procedures do so at the risk of personal injury or death.



DANGER !

Failure to properly adhere to lift these Blocking Instructions is to risk the sudden and uncontrolled descent of the lift carriage during maintenance or inspection. A falling carriage can cause severe injury or death.

I. ROUTINE MAINTENANCE (Carriage is completely lowered)

1. Remove any load from the unit.
2. Raise the platform to a convenient height.
 - A. Press the UP button and then press the EMERGENCY STOP button when the desired height is reached, OR
 - B. Use a fork truck or other lifting device to raise the platform carriage, taking care not to damage the carriage or cylinder.
3. Depending on the size of the platform carriage, insert 2, 3, or 4 empty 55-gallon steel drums, which are in good condition and of equal height, under the platform carriage to create a stable and crush-proof support. Be sure to remove any debris that may interfere with the bottom of the drums with a long-handled broom.
4. Lower the platform carriage onto the drums (or other solid, stable, and structurally adequate supports).
5. Lock out and tag the electrical disconnect.



DANGER!

To avoid personal injury or death, turn off the power and lock out the power at the primary power disconnect switch before service or maintenance per OSHA Lock-Out, Tag-Out procedures.

BLOCKING INSTRUCTIONS



DANGER !

If for any reason you are unable to lower the lift completely onto the drums, stop immediately and consult the factory at 888-811-9876. Failure to use a system of adequately stable and strong lift blocking devices could result in severe injury or death.

II. BLOCKING FOR EMERGENCY REPAIR or INSPECTION

Whenever the carriage has stopped at any elevation besides the fully lowered position and will not move using the operator pushbutton stations, the carriage must be secured against downward movement prior to beginning any inspection or troubleshooting activities that require the gates/doors to be open.

In particular, a carriage which has become wedged in the guide beams, or has become jammed by interfering with surrounding structure (landings, floor opening, door headers, backstop assemblies, etc.), may have damaged or broken the lifting chains or other critical components that are supporting the carriage. Therefore, when a carriage becomes wedged or jammed DO NOT walk out onto the carriage or attempt to physically free the carriage until the carriage has been adequately supported from beneath.

In any of these emergency conditions, safe lift blocking can be accomplished using one of these approved alternate methods while following steps I.1 through I.5 above:

1. Use a series of adequately sized adjustable jack stands around the underside perimeter of the lift carriage to provide a level, stable support
2. Use a fork truck with adequate travel, capacity, and fork width/length to provide a level, stable support
3. Use one or more steel chains of adequate length and strength to secure the overhead channel to the overhead steel tube drive base – to provide a stable, level hanging support for the carriage (**Reference Figure 10**).

NOTE: Whenever a wedged or jammed carriage condition occurs, you should call an authorized Autoquip dealer or representative to conduct a comprehensive inspection of the lift for structural and component damage before placing it back into service.

BLOCKING INSTRUCTIONS

III. BLOCKING FOR GEAR MOTOR MAINTENANCE



DANGER!

Do not remove or disconnect the motor or brake unless the platform has been adequately blocked to prevent any downward movement, a falling platform will cause serious injury or death.

Extreme caution must be taken anytime the gearbox or brake motor is disassembled. All holding and braking forces on the lifting chains are removed and the chains are allowed to “free-wheel” under their own weight or any other weight that may be on the chains, including the weight of the carriage.

Therefore, any time maintenance to the drive assembly is performed, especially when utilizing the lift carriage as the work platform, the carriage **MUST** be blocked adequately per approved blocking methods as described in paragraph II. above.



DANGER!

Only trained and qualified technicians should operate the manual brake release. With the brake disengaged, the carriage will fall uncontrollably and cause serious injury or death.

INSTALLER GUIDELINES/RESPONSIBILITIES

Proper installation of Vertical Reciprocating Conveyors (VRCs) is vital to the safety of the operators, the efficiency of the unit, and the ultimate satisfaction of the end user. These guidelines have been prepared by member companies of the Material Handling Industry's VRC Subcommittee to assist the VRC installers in understanding their role and responsibility in providing customers with a safe and reliable VRC.

1. PRE-INSTALLATION ACTIVITY

- A. Whenever possible, make a pre-installation visit or call someone at the site. Installers must be familiar with everything relative to proper installation of this equipment. It is the installer's responsibility to check the site for problems and work out solutions with the appropriate people – preferably before installation begins.
- B. Check floor-to-floor dimensions on the general arrangement drawings to make sure that they match on-site conditions. VRC's are designed and built to individual applications and specific customer requirements. It is difficult and expensive to modify the lift after it arrives for installation.
- C. Installation may or may not include unloading, permits, seismic calculations, or extensive acceptance testing. The requirements of each contract should be carefully reviewed for possible conflicts of interpretation.
- D. Each state, county, or municipality may have unique codes governing the installation and acceptance of VRC's. Acquaint yourself with the permitting and/or licensing requirements (and expenses) of the local regulatory agencies. Note also that some agencies may require inspection or testing before and/or after lift start-up.
- E. Make sure there is adequate ingress/egress to the installation site. Verify that the equipment can get through the existing doorways, halls, and shaft openings. Think through how the lift will be unloaded, carted/moved, raised into position, and accessed for installation, operation & maintenance.
- F. Verify the construction and integrity of building columns, joists, walls, or mezzanines that will be used to help support the VRC mast guide beams.

2. SHIPMENT & INITIAL INSPECTION

- A. Upon receipt of the shipment, check for exposed damage or shortages and make note of it on receiving paperwork from the trucking company, any claims for damage must be filed with the carrier. Unless otherwise stated, the VRC Manufacturer is not responsible for parts lost, stolen or damaged during transportation, storage, or installation.

INSTALLER GUIDELINES/RESPONSIBILITIES

- B. Assuming no damage has occurred to the crate, check the components against the packing list. This will provide assurance that every item shipped has been received.
- C. Make sure you have a copy of the latest version of the general arrangement and electrical drawings before beginning installation, changes could have been made since original purchase order submittal and order entry.
- D. Read and understand this manual thoroughly prior to starting the installation.

3. EQUIPMENT LAYOUT

- A. Make sure pit and/or lift are properly squared and vertically aligned with upper landings to ensure that the carriage will clear the upper landings by the required distance.
- B. Be sure to take into consideration any other obstructions (pipes, ductwork, ceiling joists/beams, etc.) that may be located around the lift.
- C. Inspect the installation for any overhanging floor landing or other obstruction (pipes, ductwork, ceiling joists/beams, etc.) which could potentially jam a load that is slightly overhanging the carriage deck as it raises to the next floor level. Any potential jam point should have some type of slanted or beveled guarding placed beneath the obstruction to push the overhanging load back onto the carriage.

4. STRUCTURAL INSTALLATION

- A. Follow the bracing recommendations shown on the general arrangement drawings and in the Installation & Service manual. Site conditions may also require customization to standard anchoring and bracing. The installers are ultimately responsible for the proper and safe anchoring and bracing of the equipment and should consult the manufacturer if there is any doubt as to the structural integrity of the installation.
- B. When anchoring guide beams to walls, you must be sure that the walls can support the reaction loads imparted on them.
- C. If spliced masts are provided, be sure to assemble and field install them exactly to the Manufacturer's recommendations. Failure to do so will reduce the safety and performance of the VRC. See **Installation** Section for acceptable limits.
- D. Make sure guide beam pairs are plumb, parallel, and straight after you are finished with all welding. See **Installation** Section for acceptable limits.
- E. Do not modify any component of the lift without expressed written consent from the Manufacturer.

INSTALLER GUIDELINES/RESPONSIBILITIES

5. MECHANICAL INSTALLATION

- A. Most work can be done with the lift carriage fully lowered. Never work under the lift carriage unless it is blocked in place per the “Blocking Instructions” section of this manual.
- B. Never allow a person to ride on the carriage of the lift.
- C. Use only the hardware supplied by the Manufacturer to assemble the lift. This hardware is often high grade, some hardware is metric.
- D. Do not remove or disconnect the motor brake on mechanical drives unless carriage and lifting chains are secured and properly supported per the “Blocking Instructions” section of this manual..
- E. Check gearbox fluid levels before starting up mechanical drive units. Failure to do so will reduce the effectiveness and safety of the lift.
- F. Use only the lifting chains and attachment hardware supplied by the Manufacturer.

6. ELECTRICAL INSTALLATION

- A. Ensure that the supplied voltage matches the motor supplied.
- B. Make sure that the customer-supplied electrical disconnect is a fused-type disconnect and is installed within direct line of sight of the lift it is associated with.
- C. All electrical work must meet the requirements of ASME B20.1 as well as all state and local codes.
- D. Make sure that only qualified electricians perform all wiring and that they are familiar with the electrical drawings shipped with the equipment.
- E. Do not operate the lift until the carriage is leveled and the guide beams are plumbed and secure.
- F. Never operate the lift by “manualling” the electrical controls (using the contactors located inside the control panel). All safety devices are by-passed in this mode of operation and lift damage or severe personal injury could occur.
- G. Do not operate the lift using the operator pushbuttons prior to having all safety devices and/or gate interlocks wired and in the circuit. Never by-pass any safety device and/or interlock.
- H. Electrician to ensure that motor brake wiring is complete when wiring the motor.

INSTALLER GUIDELINES/RESPONSIBILITIES

- I. Operator pushbutton stations must not be operable from the carriage with the gate(s) or door(s) closed, and should be located at least 6 feet away from the carriage platform.
- J. Per OSHA requirements, the motor control panel must be mounted in a location that is visible from the lift.
- K. Always follow OSHA lock-out, tag-out procedures when the lift being maintained, serviced, or inspected.

7. PERSONNEL & EQUIPMENT SAFETIES

- A. ASME B20.1 requires that all VRC installations be completely guarded to prevent injury from inadvertent contact with the lift or its load. ASME also requires that doors or gates at all unloading stations be interlocked so that these doors can only be opened when the lift carriage is stopped at that level & that the carriage is incapable of being operated or moved so long as these doors or gates remain open. It is the responsibility of the installer to ensure that the installation meet these requirements, regardless of who (manufacturer, customer, architect, general contractor, etc.) provides the doors/gates and means of enclosure. Consult Autoquip whenever there is a question as to whether or not the gate & enclosure installation meets ASME B20.1.
- B. Where the application requires personnel to walk onto the carriage in the raised position, the installer must ensure that the carriage is adequately provided with railings, guards, and snap chains that are a minimum of 42" high.
- C. Travel limit switches, slack chain sensors, and over travel sensors (for mechanical units) must be installed and working properly. See **Installation** section of this manual.
- D. Ensure proper operation and engagement of motor and carriage brake assemblies.

8. TESTING

- A. Test up and down speeds.
- B. Test all electrical switches and sensors, gate interlocks, gate status switches, and any other safety features or devices as described in the **Installation** section of this manual. Also consult any manuals which may have been shipped separately for the gate installation & operation.
- C. Some states or municipalities may require testing of the carriage free-fall arrest system (locking cams) – consult the local regulatory agency or the manufacturer.

INSTALLER GUIDELINES/RESPONSIBILITIES

9. CLEAN-UP & HAND-OFF

- A. Conduct a final inspection of the lift installation using the Installation Checklist in the **Appendix** of this manual. Correct any deficiencies before clean-up & hand-off.
- B. Apply proper signage to all locations of the installation per the guidelines in the **Label Identification** section and per any instructions shipped separately with the gate interlock kits. Contact Autoquip at 888-811-9876 if labels appear to be missing or damaged.
- C. Train key personnel on the operation of the system and all safety features and procedures by referencing the corresponding sections in this manual.

INSTALLATION INSTRUCTIONS

THE TOOLS REQUIRED FOR INSTALLATION

Listed below are some of the tools needed to install the FREIGHTLIFT in a professional and prompt manner. Individual site situations and a basic variation in the types of units may dictate the need for additional items.

Welding Machine and Equipment	Hack Saw, Sawzall, or
Cutting Torch with Full Tanks	Portable Band Saw
Fire Extinguisher	Drill and Drill Bits
Forklift	Extension Cords
Chain Fall	Sledge Hammer
Come-A-Long	Open or box end wrench
Cables or Hook Chains with 1,000# Cap.	Drift Punch
Disk Grinder	Carpenter's Square
"C" Clamps (12" opening)	Chalk Line
Socket Set (1/2" drive, sockets to 1 1/8")	Plumb Bobs
Pinch Bar	4' Level
Hammer Drill & Bits for 1/4", 3/8" and 1/2" anchors	25' / 100' Measuring Tapes
	Broom

The following supplies will also be needed:

*Concrete anchors (8 minimum) sized for the required minimum pullout of the base floor channels and upper level bracing. Refer to the approval drawing since the size of the anchors can vary for each installation.

*Concrete anchors for accessories, such as enclosures, approach ramps, etc. (Usually 1/4" diameter anchors and at least 12 anchors, minimum.)

*Shim stock for the floor channel, platform carriage corners, and/or approach ramp (if a part of this installation)

*Paint (Autoquip Blue: available in 1 and 5 gallons, as well as spray cans)

*3" x 3" steel angle iron or 4" channel for additional bracing

ALSO - BEFORE YOU BEGIN :

1. Beams are too heavy to lift manually and require lifting equipment. Check for availability of overhead attachment of chain fall or of fork truck before you start.
2. Before you will be able to complete the installation the unit must be operated, therefore power to the motor is required. Arrange for power before starting installation.

INSTALLATION INSTRUCTIONS

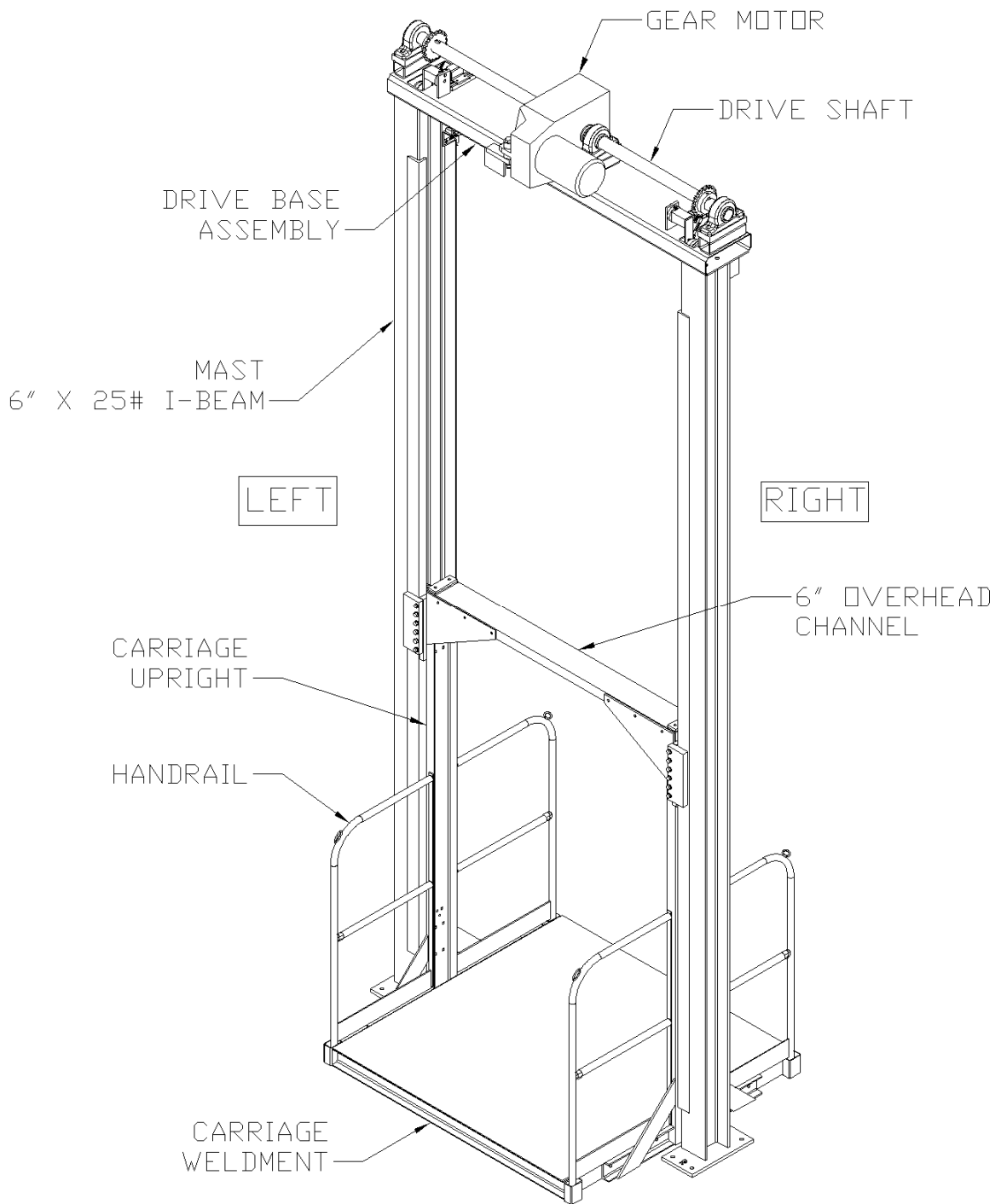

Figure 10 – Identification of Parts, FLM

INSTALLATION INSTRUCTIONS

NOTE: All illustrations contained in this manual are for reference purposes only. Specific applications and site conditions may require different anchoring and bracing procedures. The ultimate responsibility for the anchoring and bracing rests with the installation crew.

A. LAYING OUT CARRIAGE POSITION & MARKING FLOORS FOR ALLIGNMENT

1. Refer to **Figures 11 - 16** to lay out and mark the reference lines so that the lift will clear the upper landing and any obstructions that may be located around the lift (the General Arrangement Record Drawings should indicate the necessary clearance needed for the particular application).
 - a. **Figure 11** - Layout the position of the lift at the second level landing/opening, marking the center of the carriage first – then both outside edges of the carriage.
 - b. **Figures 12 & 13** - Drop a plumb line from the center marking of the carriage position at the second floor holding the plumb line one inch out from the edge of the landing (one inch is a standard distance for clearance - deviations may occur), or point A, down to the first floor and mark point B as the carriage center (check the GA drawing for any other special considerations).

NOTE: To ensure carriage clearance between floors, remove any protrusions from the floor, wall, etc., or move the plumb lines out beyond the protrusions.

- c. **Figure 14** - Drop plumb lines from the upper level to the lower level using the two markings identifying the outside edges of the carriage platform. Again, the plumb line must be held 1” out from the edge of the mezzanine or opening at the second floor to provide adequate clearance.
 - d. **Figure 15** - Using a chalk line, snap a line between C and D.

NOTE: The carriage will be aligned to this point. Also, always check the pit and floor openings for correct dimensions and squareness.

INSTALLATION INSTRUCTIONS

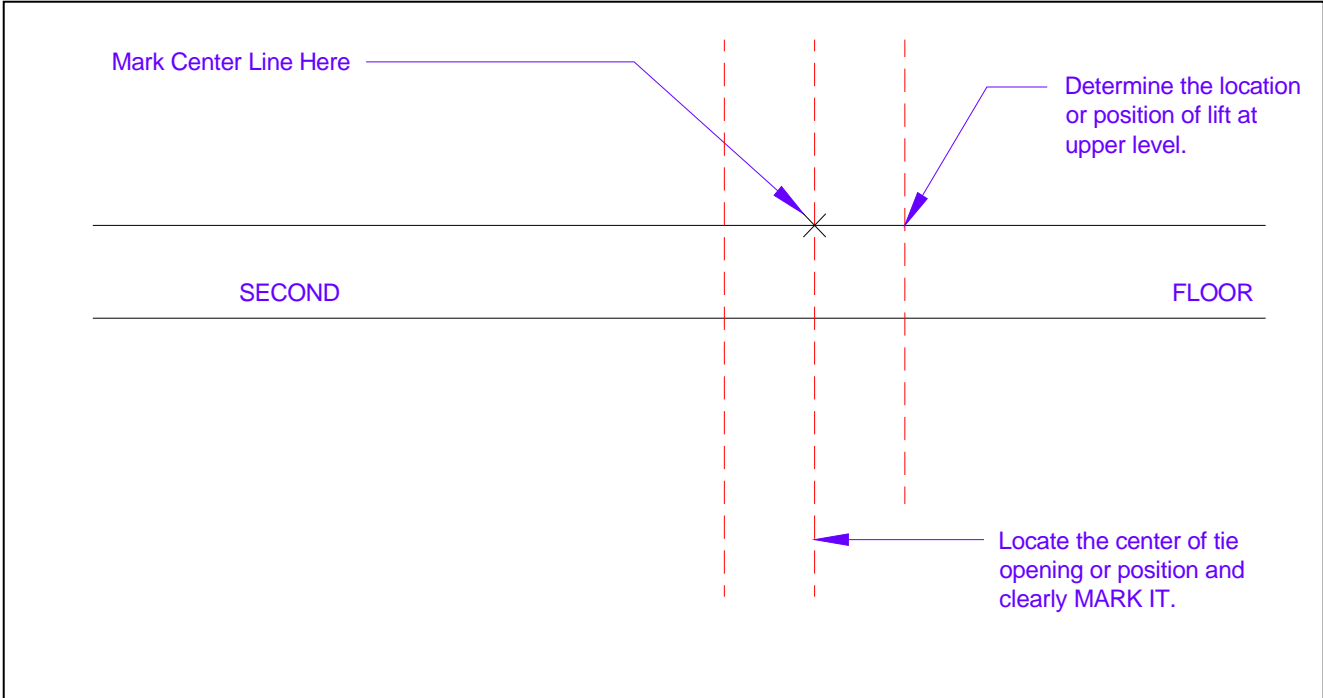

Figure 11 Marking the 2nd Floor for Carriage Position (Front View)

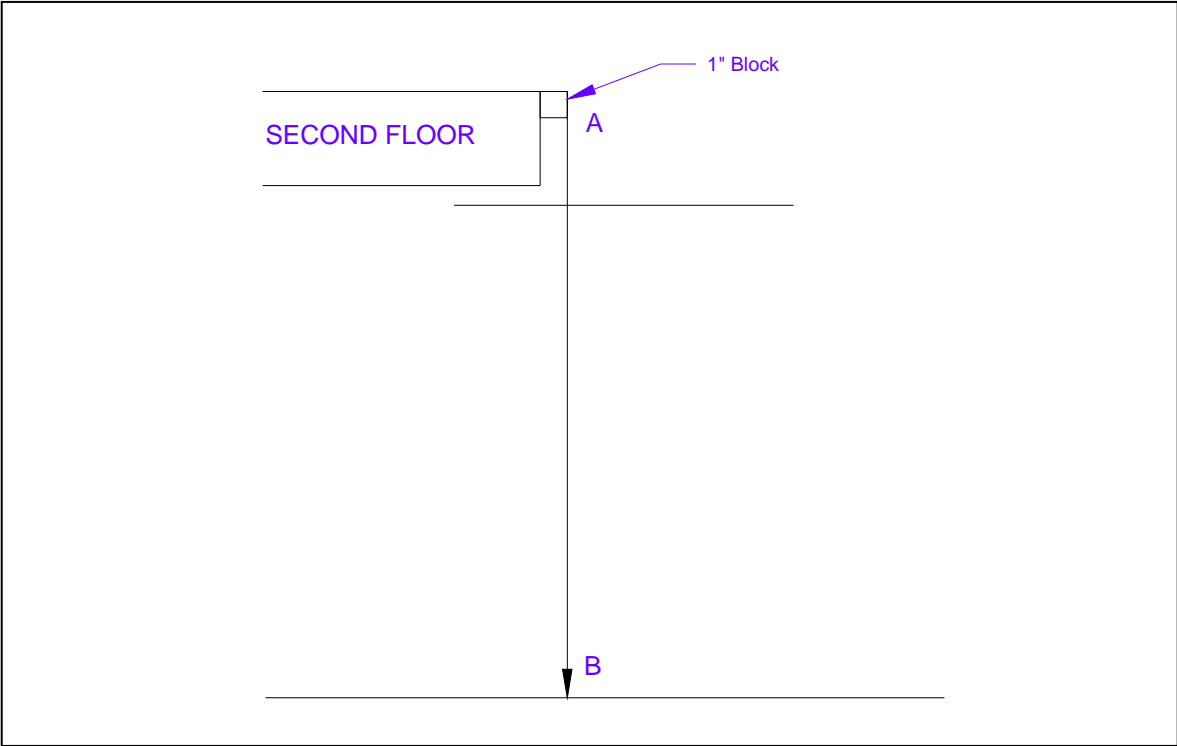

Figure 12 Locating Center of Carriage Edge on the First Floor (Side View)

INSTALLATION INSTRUCTIONS

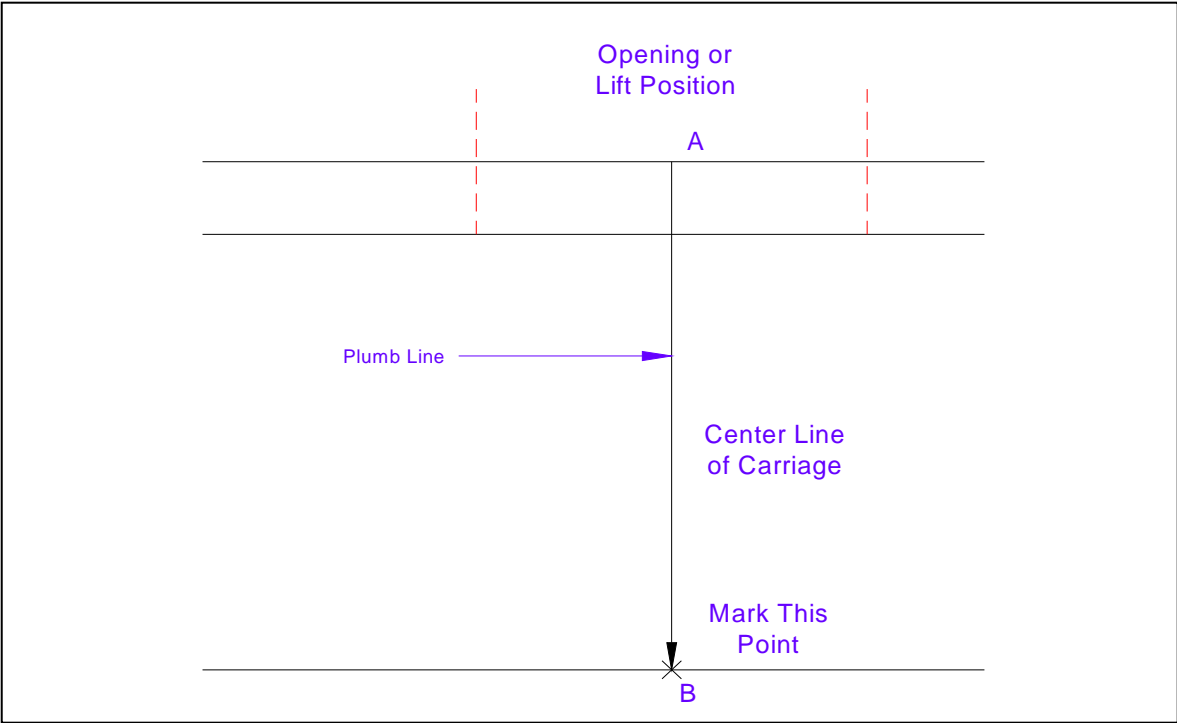

Figure 13 Locating Center of Carriage Edge on the First Floor (Front View)

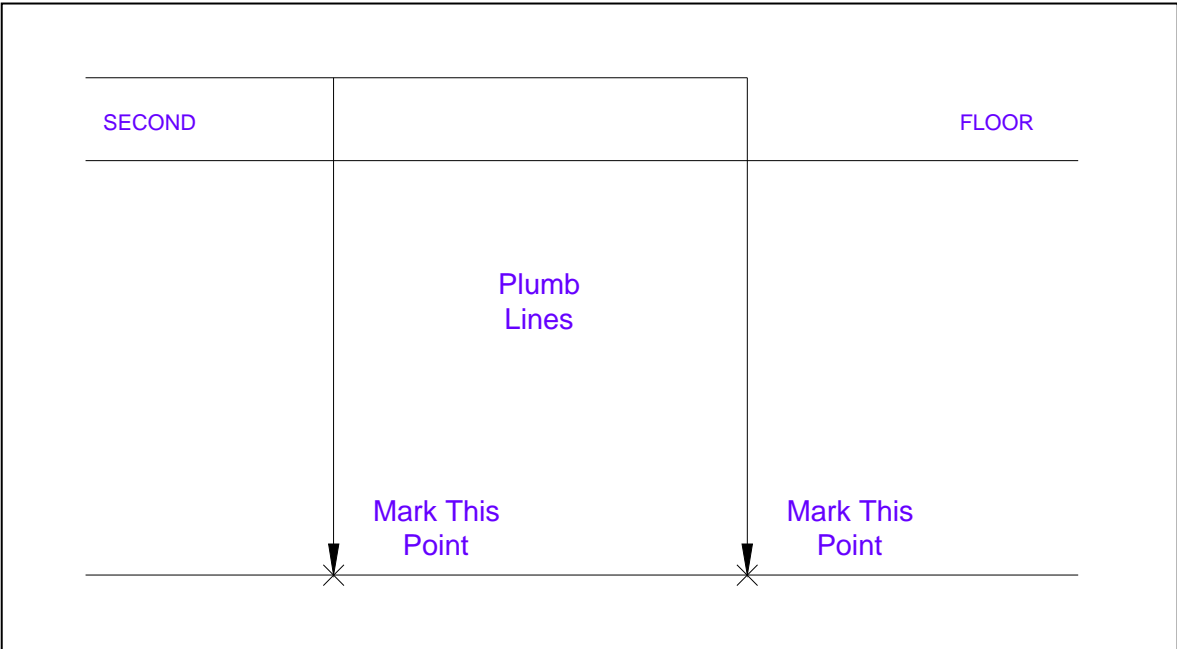

Figure 14 Locating Outside Edges of Carriage at the First Floor (Front View)

INSTALLATION INSTRUCTIONS

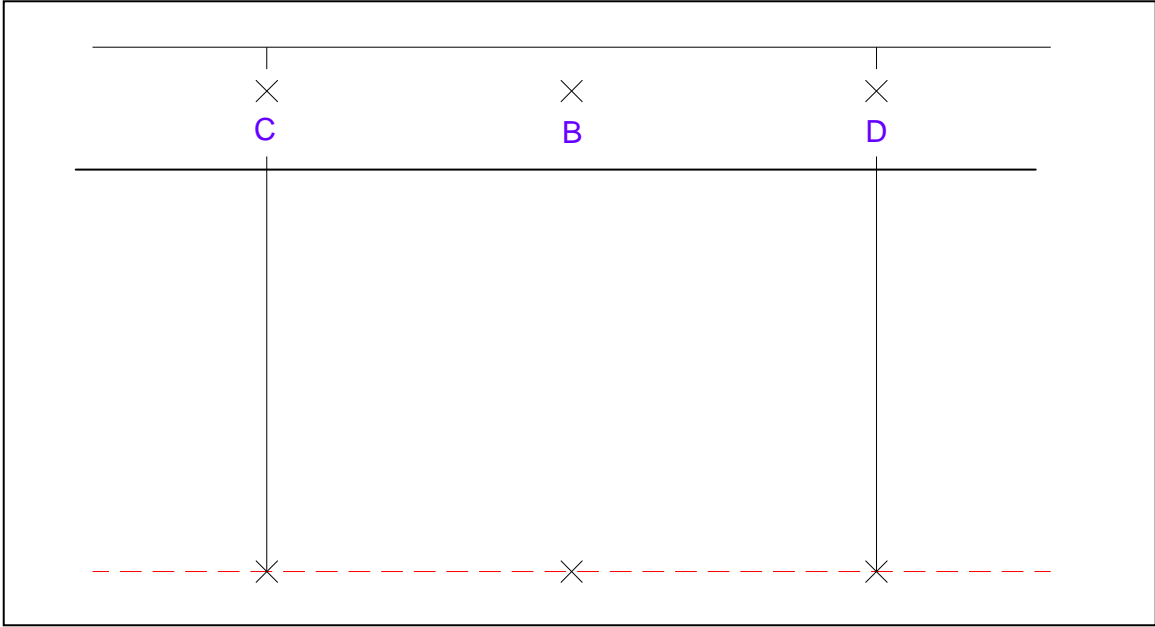

Figure 15 Chalking the Edge of the Carriage at the First Floor (Front View)

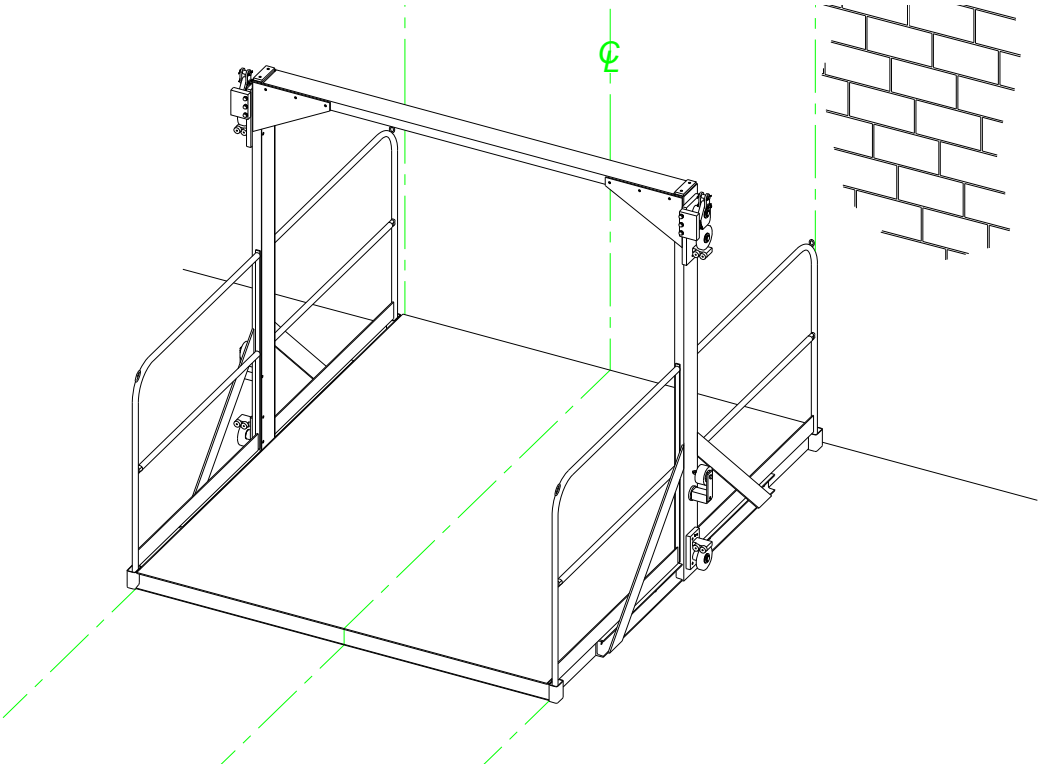

Figure 16 Aligning the Carriage with the Chalk Lines

INSTALLATION INSTRUCTIONS

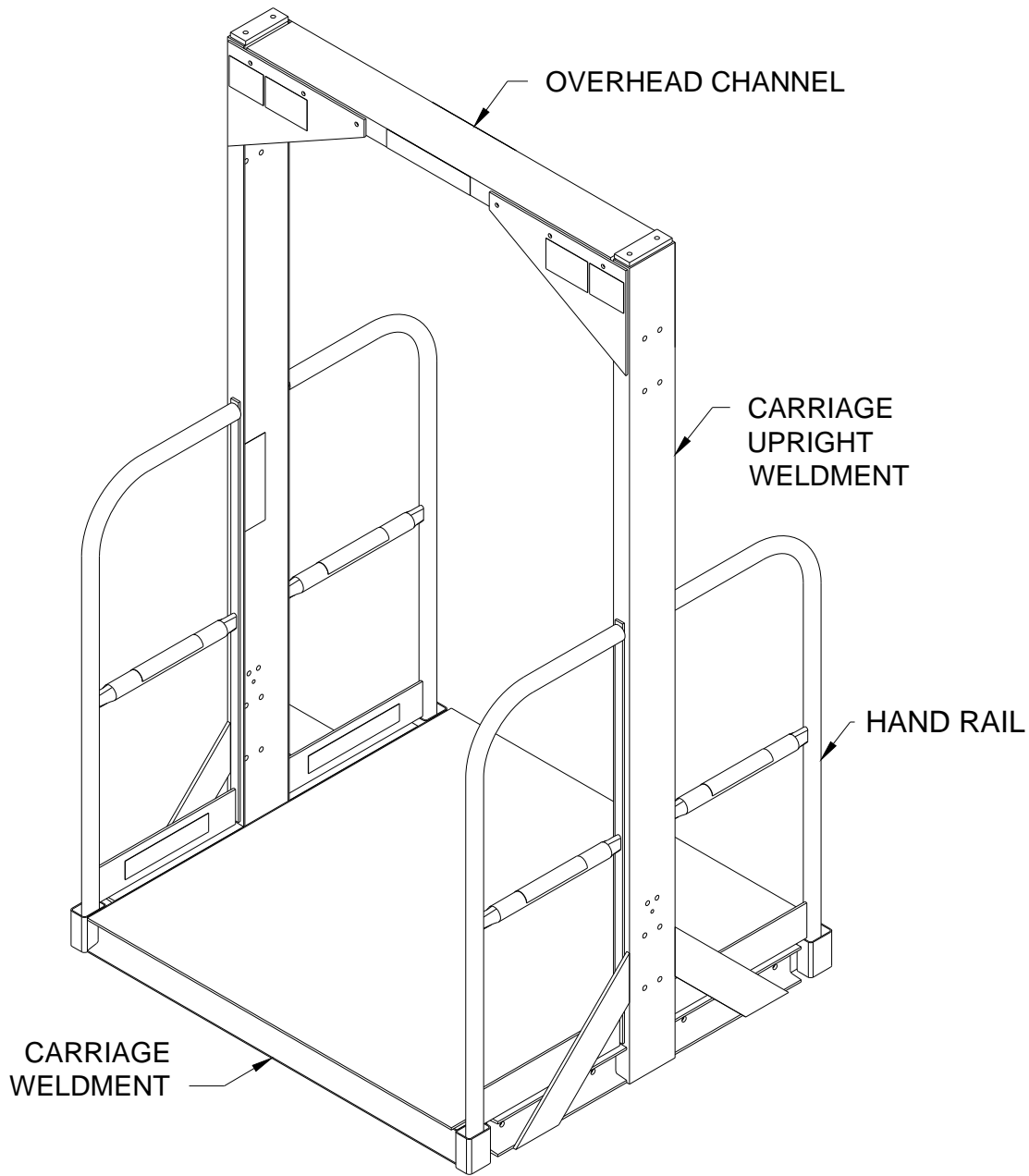

Figure 17 Carriage Assembly

INSTALLATION INSTRUCTIONS

B. CARRIAGE ASSEMBLY (Reference Figures 16 through 18)

Items needed:

<u>Qty</u>	<u>Description</u>
1	Carriage Weldment or
2	Pre-Drilled Carriage Weldment Halves (when carriage is split)
2	Carriage Upright Weldments
1	Overhead Channel (with holes pre-drilled)
4	Handrails or Expanded Metal Side Guards
1	End Rail (when ordered – for “C” load pattern)
1-2	Snap Chains – lengths vary with platform width
20 - 24	1/2" x 1-1/2"L grade 8 Hex Head Cap Screws, Washers & Nuts
2	Carriage Tie Channels (when carriage is spliced)
varies	Hardware Kits for Spliced Carriages

1. Block platform weldment at a convenient work height to permit access to the underside of the carriage.
2. Attach the Carriage Upright weldments to the carriage deck with the 1/2" grade 8 bolts, nuts and washers provided. Upright weldments are identical – there is no right and left. Torque bolts to 99 ft. lbs.
3. Attach Overhead Channel to the top, carriage upright gusset plates with the 3/8" grade 8 bolts, nuts, bevel washers, flat and lock washers provided. Torque 26 ft. lbs.
4. Attach handrails or side guard panels by positioning as shown in **Fig. 17** and/or the General Arrangement drawing, and welding into place with a minimum 1/4" fillet, 2" on 10". Grind welds and touch up the paint where necessary.
5. Attach snap chain(s) across open operating ends by using the repair link to permanently attach one end of the snap chain assembly to the open link welded to the handrail.
6. Set the carriage onto the floor at the lower level position as shown on the General Arrangement (GA) Drawing. The center of the carriage must be aligned with the “B” mark (refer to **Figure 16**). Make sure carriage is level, shim as necessary.
7. For Pit Mounted Lifts - the pit has been poured 1/2" – 3/4" deeper than the total thickness of the carriage platform for shim and grout as required.
8. For Through-Floor or Shaft Installations – when clearances are tight, you may choose to position the carriage after the beams have been assembled and raised into place. For these installations, refer to **Figure 18** to see how to properly lay out and locate the beams prior to setting the carriage.

INSTALLATION INSTRUCTIONS

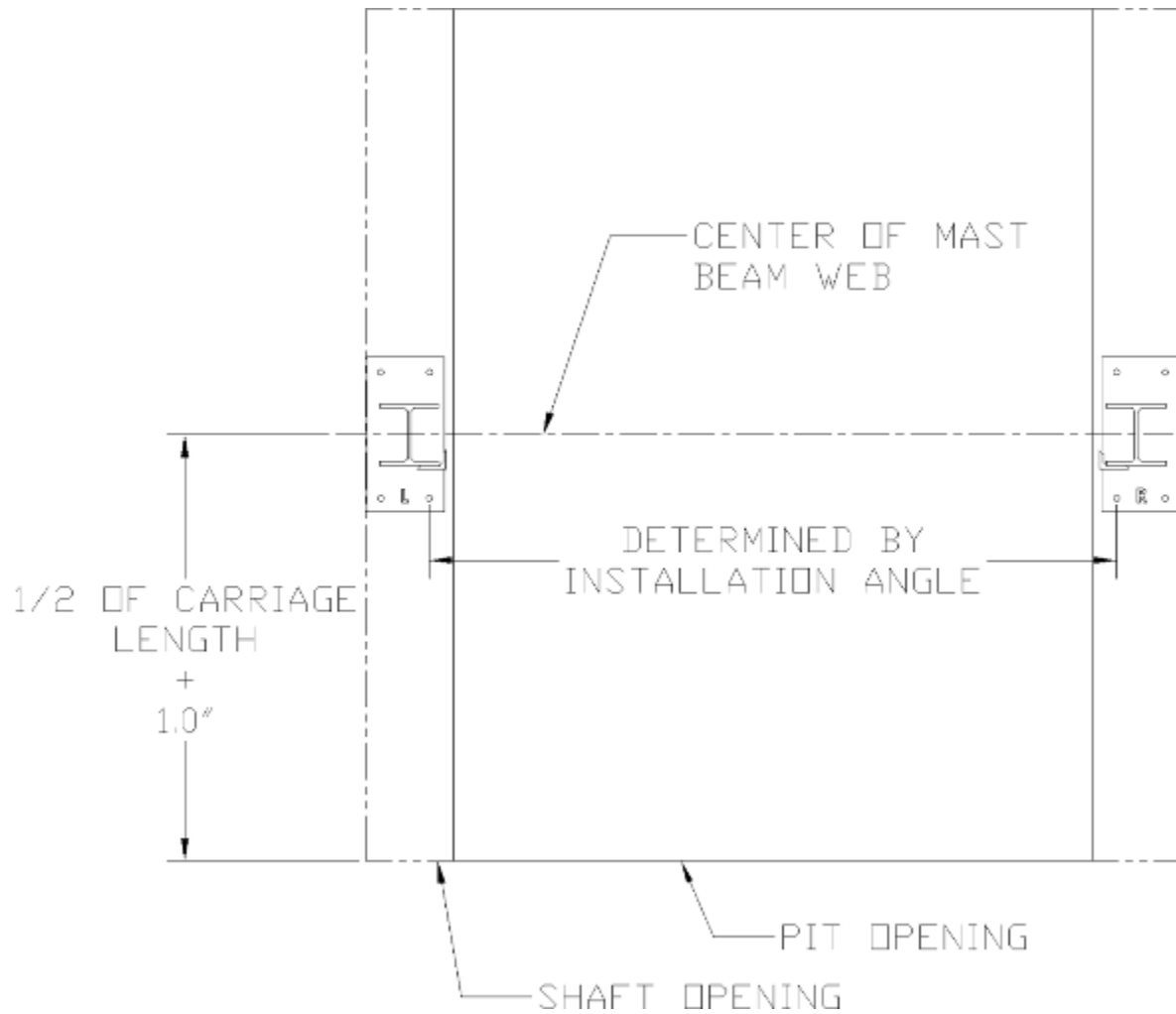

**Figure 18 Layout of Mast Foot Plates Prior to Setting Carriage
(When necessary for some Pit/Shaft installations)**

INSTALLATION INSTRUCTIONS

C. POSITIONING WHEEL GUIDE ASSEMBLIES (Reference Figures 19 and 20)

Items Needed:

<u>Qty</u>	<u>Description</u>
2	Mast Beams – Left & Right
2	Upper Wheel Guides – left & right (“L” & “R” on the assembly)
2	Chain Adaptors
4	Cotter Pins
2	Chain Adaptor Pins (with cotter pin holes)
2	Master Links (chain size varies)

1. Place the upper wheel guide assemblies in the beam as shown in **Figure 19a** by sliding them into the beam running space from below the guide angle near the bottom of the mast beam.

NOTE: This step must be done first due to the limited access space once the wheel guides are inside the guide beams & behind guide angles.

2. Attach the lifting chains to the chain adaptors and the chain adaptors to the upper wheel guide locking cams using the high strength adaptor pins and cotter pins provided as shown in **Figure 19b**.
3. Pull on the chain where it attaches to the wheel guide assembly. Slide the wheel guide assembly down the beam until it is approximately seven (7) feet from the bottom of the beam. The upper wheel guide blocks should then be positioned so that they will align with the uppermost sets of holes in the carriage uprights once the beam is raised into position.

NOTE: The safety cams will attempt to engage as you move them down the beam. Rotate and hold them in a disengaged position while you slide them into position.

4. Locate the ship-loose 3/4" x 1-1/2" x 11-1/4" flat bar and position between the carriage upright and wheel guide as shown in **Figure 20**. Weld this bar to the wheel guide as shown, then unbolt the wheel guide back-up bar from the wheel guide to complete the welding on the inside of these parts. Grind this weld as needed to re-bolt weldment to the wheel guide.

NOTE: Do not weld between the reinforcement bar and the carriage upright.

NOTE: These reinforcement bars are not optional !! The bars are absolutely necessary to resist damage to the wheel guides if the locking cams should have to be used in a free-fall arrest situation.

INSTALLATION INSTRUCTIONS

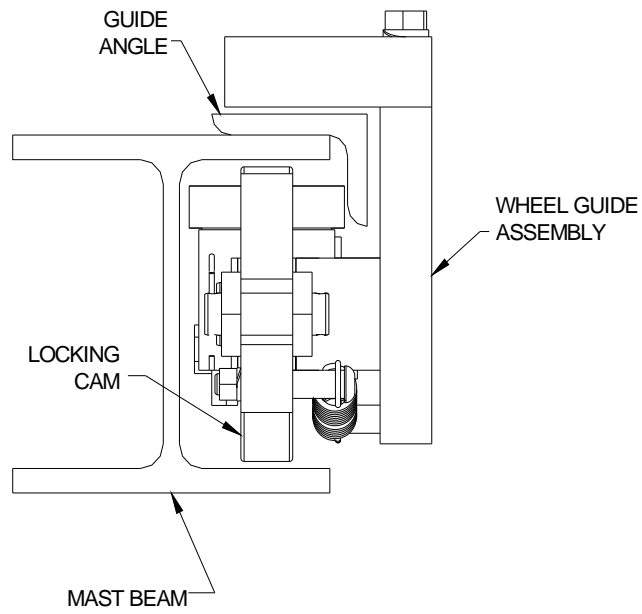

Figure 19a Upper Wheel Guide Assembly in Mast Beam (Top View)

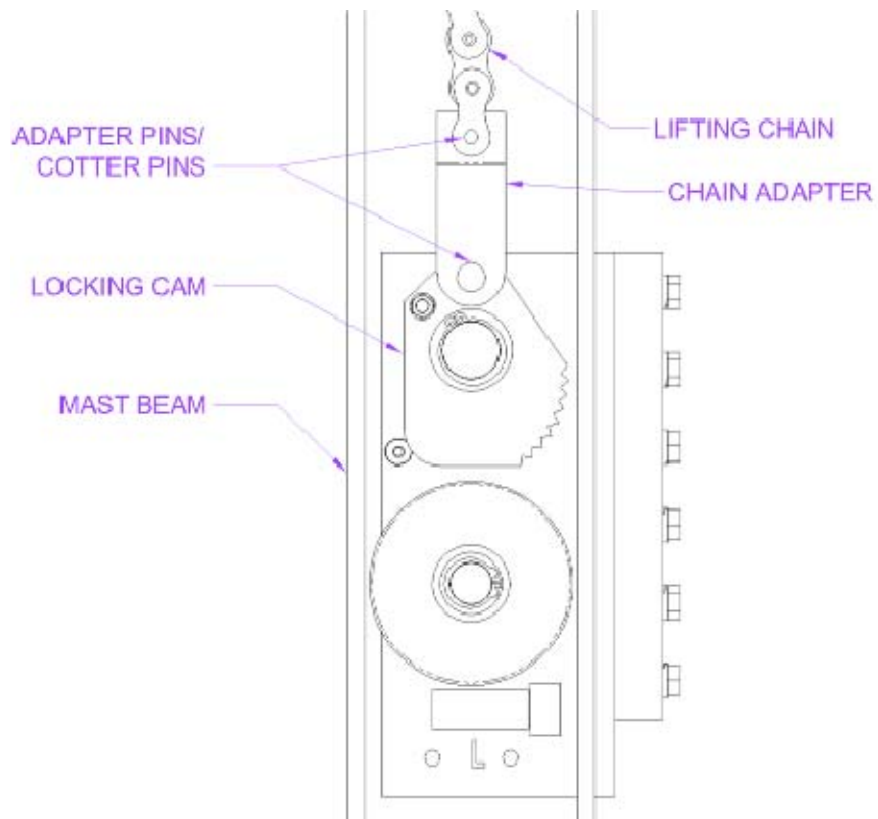

Figure 19b Upper Wheel Guide Assembly in Mast Beam (Side View)

INSTALLATION INSTRUCTIONS

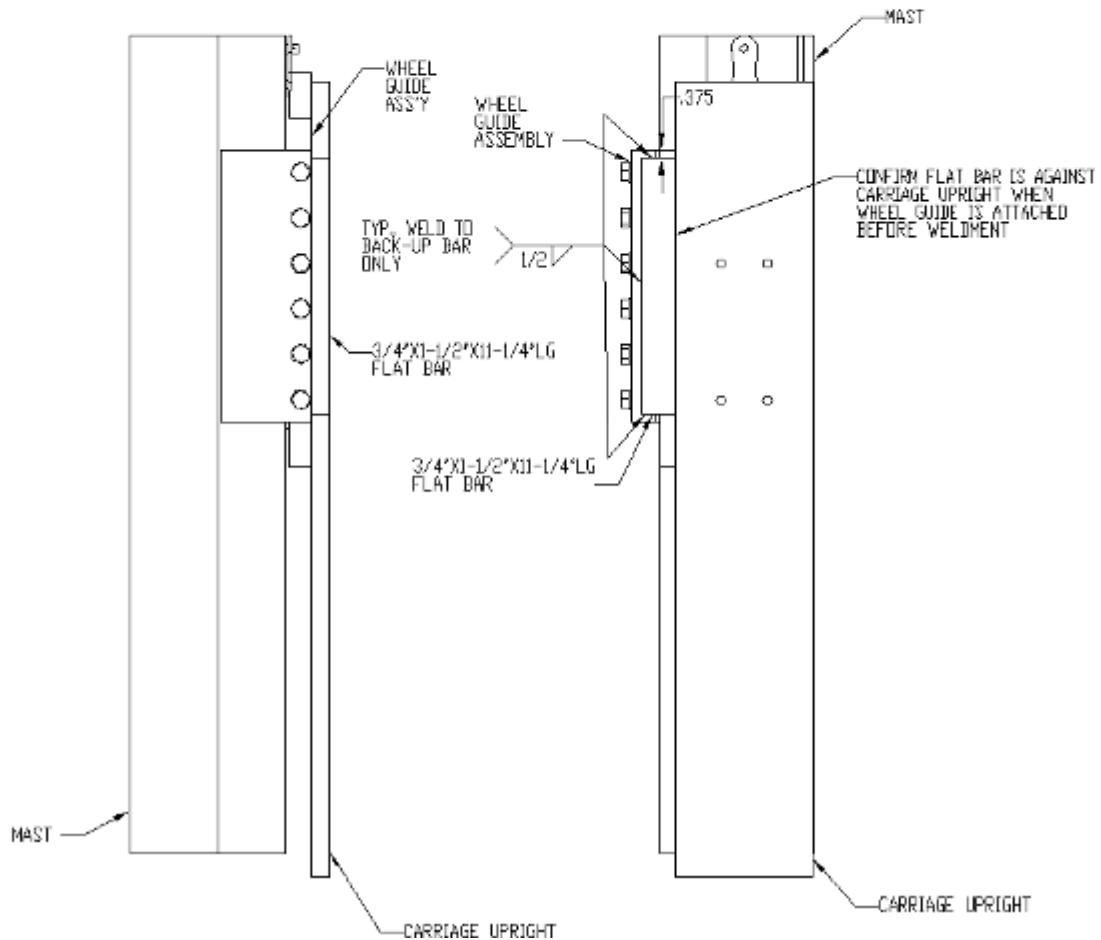
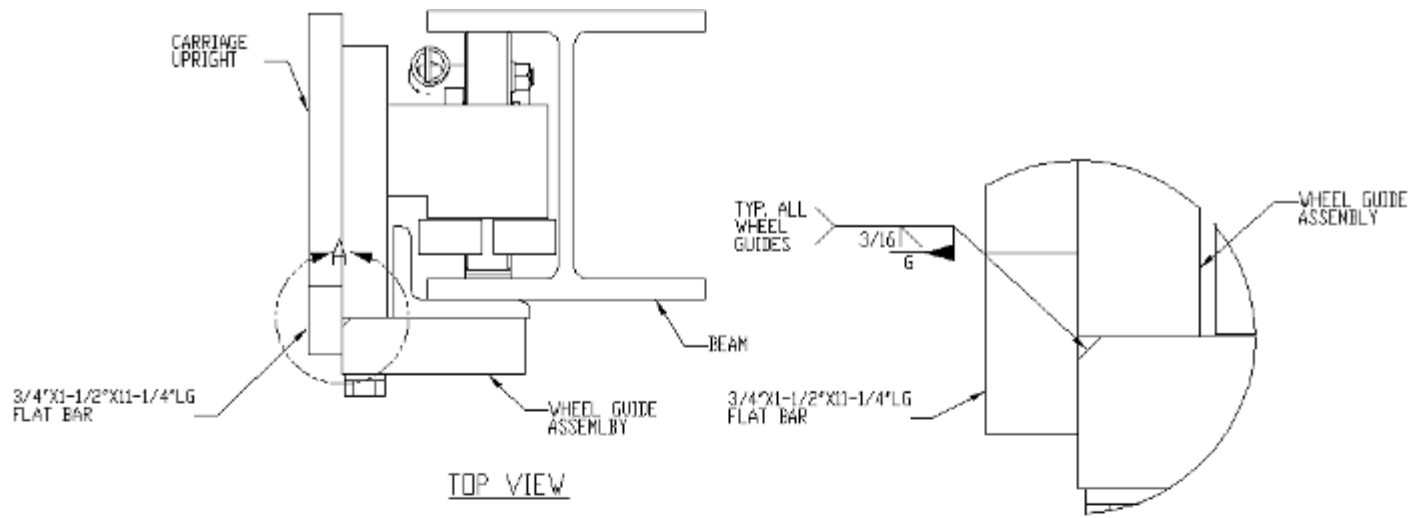

Figure 20 Upper Wheel Guides – Field Welding of Reinforcement Bars

INSTALLATION INSTRUCTIONS

D. RAISING THE BEAMS & WHEEL GUIDES (Reference Figures 21 through 23)

Items Needed:

<u>Qty</u>	<u>Description</u>
2	Lower Wheel Blocks (left & right)
2	Wheel Tensioner Assemblies with Metric mounting bolts
1	Installation Angle (with bolts in each end) – if needed
16	1/2" x 1-1/2"L grade 8 Hex Head Cap Screws, Washers & Nuts

1. Raise the beams into position (see **Figure 21**). The mast beam assemblies are designated either "left hand side" or, "right hand side" (there is a welded "L" or "R" marked on the mast beam base plate). The left hand side is to your left and the right hand side to your right as you stand at the upper level (or with your back against the bracing wall) facing the beams (the guide angles are always towards you).
2. Install one wheel tensioner assembly per side using the dedicated metric bolts, torque to 63 ft. lbs. as shown. Roller is oriented away from the mast guide angle when rotated into position for bolting
3. Position the lower wheel blocks into their respective beams by tipping the blocks and allowing the rollers to fit inside the guide angles. Then, insert the guide wheel into the opening at the bottom of the beams.
4. Slide the right hand beam into position along side the carriage. Both upper and lower wheel guide assemblies should align with their respective mounting holes on the carriage uprights. Bolt the wheel guide assemblies to the uprights using the 1/2" x 1-1/2"L grade 8 bolts and the 1/2" washers that have been provided. Torque all these bolts to 99 ft. lbs. as shown in **Figure 22**.

NOTE: Make absolutely sure the beam is secure with chain or temporary bracing.



WARNING!

Do not depend on the carriage uprights and wheel blocks to support the beam! Use other means to support and secure the beams in the raised position during installation and prior to final bracing. Improperly or inadequately supported beams could fall and cause serious injury to adjacent personnel or permanent damage to the equipment.

5. Repeat the previous step to position and secure the left hand beam.
6. The installation angle shipped with your unit can be used to properly space the two beams apart temporarily, prior to setting the carriage or securing beams to floor.

INSTALLATION INSTRUCTIONS

SPLICED BEAMS (when used)

1. Set the upper mast on its respective lower mast (plates & beams are marked) in the orientation shown on **Figure 23**, taking necessary precautions not to bend or damage transition plates.
2. Verify that both beams are true, straight, and plumb within 1/8" over any 10 foot span and not to exceed 3/8" over the entire length of the beam.
NOTE: This tolerance may not be exceeded or immediate & permanent damage to the hardened wheel guide wheels will occur. (Shim material by installer).
3. Once both beams are verified to be straight & plumb as specified as above, permanently weld the upper & lower mast assemblies together as shown. Weld distortion to the beams must be minimized to hold the required tolerance to beam straightness.

NOTE: Care should be exercised not to distort the masts from welding, and alignment is critical. Grind the guide beam to provide a smooth surface for the guide wheels and rollers.

NOTE: Beams must be plumb and parallel within 3/8" overall before proceeding with permanent bracing. The beams MUST be within this tolerance or the guide wheel assemblies will fail prematurely.

INSTALLATION INSTRUCTIONS

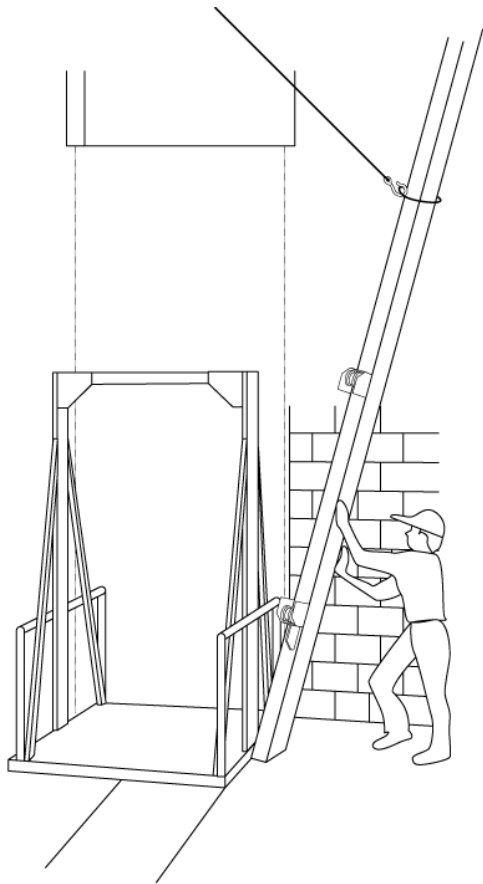

**MAKE SURE
THE BEAM IS
WELL SECURED**

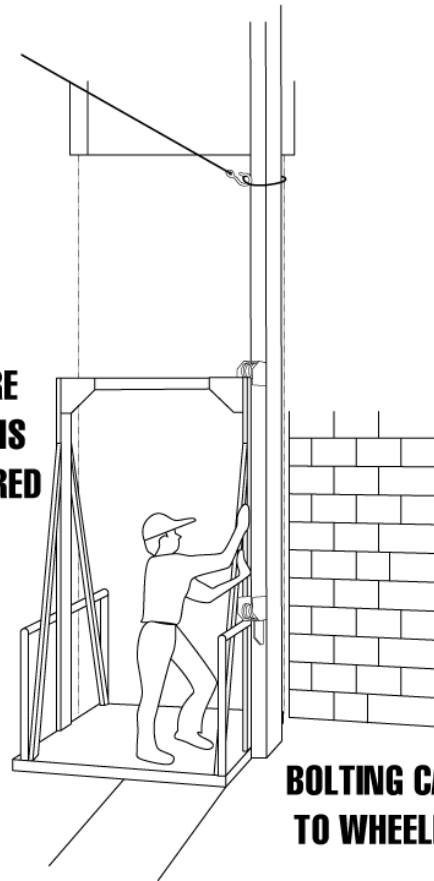

**BOLTING CARRIAGE
TO WHEELBLOCKS**

Figure 21 Raising the Mast Beams

INSTALLATION INSTRUCTIONS

BOLTS FOR UPPER & LOWER WHEEL GUIDE ASSEMBLIES – TORQUE TO 99 FT-LBS.

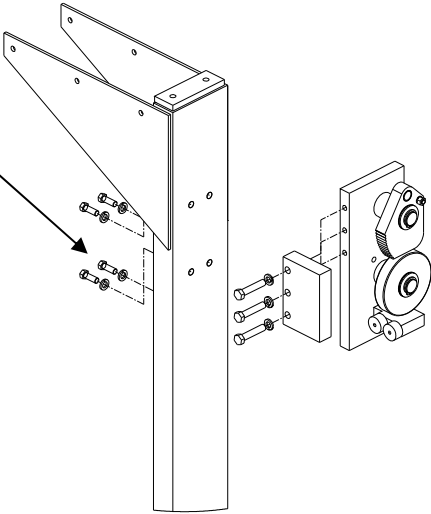
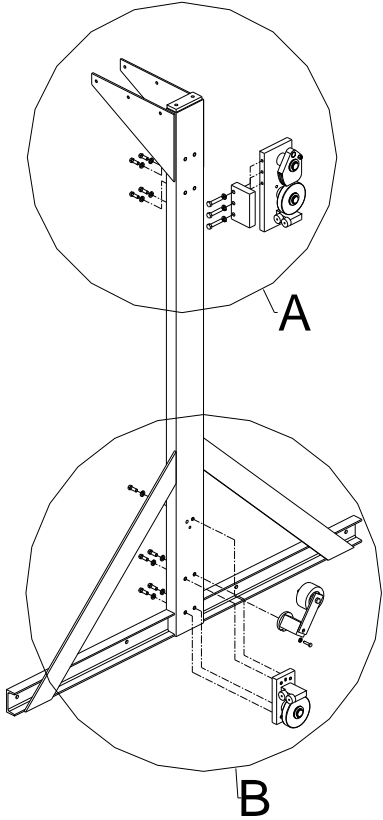

DETAIL - A

TENSIONER MTG BOLT (METRIC THREAD)
TORQUE TO 63 FT - LBS.

BOLTS FOR UPPER & LOWER WHEEL GUIDE ASSEMBLIES – TORQUE TO 99 FT-LBS.

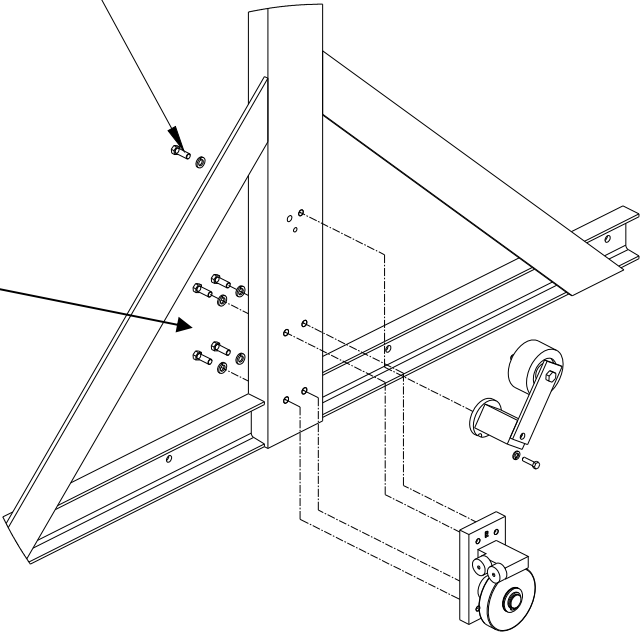

DETAIL - B

Figure 22 Wheel Block & Spring Tensioner Mounting Detail

INSTALLATION INSTRUCTIONS

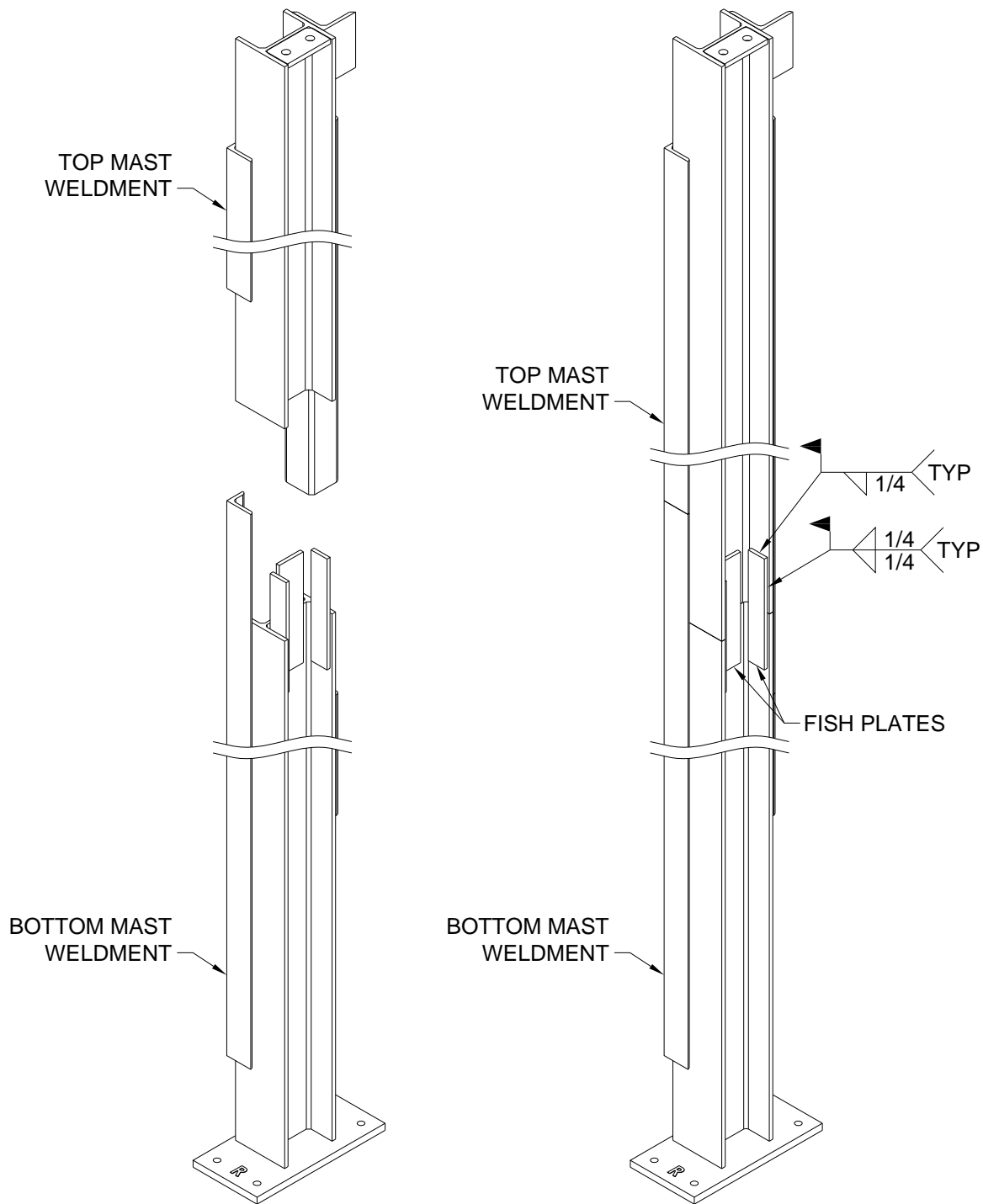

Figure 23 Mast Splice Detail

INSTALLATION INSTRUCTIONS

E. DRIVE BASE INSTALLATION & SECURING THE MASTS (Reference Figure 24)

Items needed:

<u>Qty</u>	<u>Description</u>
1	Drive Base w/Gearmotor, Shaft, Bearings & Sprockets
4	3/4" x 2-1/4"L, Grade 8 Hex Head Cap Screw, Washer, and Nuts

1. Raise the drive base into position above the mast beams in the orientation shown in **Figure 24** and bolt into place using the hardware provided. Tighten bolts snug at this point.

NOTE: Alignment of the main beams is very important! Check the guide angle dimension (from bottom to top) against those shown in the job-specific General Arrangement / Record drawing.

2. Recheck the position of the beams and ensure that the beams are not twisted or turned, and that they are also plumb, parallel, square, and level (beam pairs mounted in pit floors must be checked closely for level because pit floors may not be poured level). To maintain proper positioning of the beams – shim under each mast foot plate as required to fill any gaps between the foot plate and the floor which may have been created during the plumb-square-level process. Torque bolts on the drive base to 99 ft-lbs.

NOTE: Beams must be plumb and parallel within 3/8" over the entire length of beam before proceeding with permanent bracing. The beams MUST be within this tolerance or the guide wheel assemblies will fail prematurely.

3. Remove the installation angle (if used).
4. Lag the beams to the floor using four (4) bolts for each mast beam plate – sized to withstand the pull-out force specified on the GA drawing. Torque to 99 ft-lbs.

INSTALLATION INSTRUCTIONS

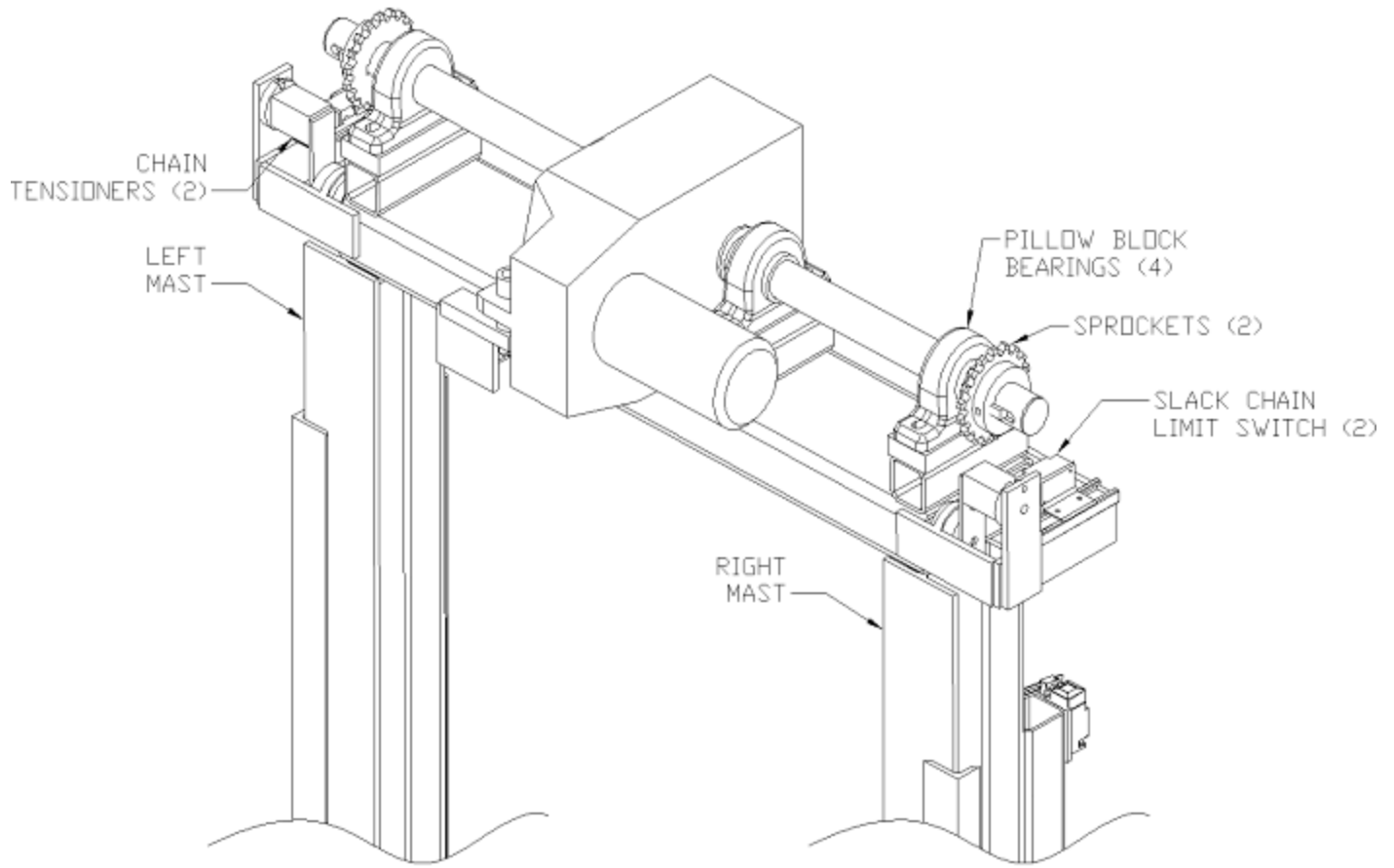

Figure 24 Drive Base Attachment

INSTALLATION INSTRUCTIONS

F. BRACING THE BEAMS (Reference Figure 25)

All illustrations on the GA drawing for bracing preferences are for reference only. Site conditions may require different anchoring and bracing. The installers are ultimately responsible for the proper and safe anchoring and bracing of the equipment. *Autoquip Corporation* supplies material for bracing on standard applications, but special bracing may be required by the installer on non-standard models. The special materials for anchoring and bracing of the lift and gates are not the responsibility of *Autoquip*.

NOTE: For all field welding of braces, use 1/4" fillet – all around.

Items needed:

<u>Qty</u>	<u>Description</u>
Varies	Horizontal Brace Channel
varies	Diagonal Channel Brace (when applicable)
varies	Brace Plates – with (4) 9/16" dia. holes each
varies	Side Channel Brace (when applicable)

HORIZONTAL / UPPER LEVEL BRACING

1. Attach the horizontal channel brace to the upper floor landings with either lags or by welding (it has been assumed that you will have a solid floor face to attach to for your installation). When attaching the floor to beam brace, use bolts which have been properly sized to withstand the horizontal pull-out force shown on the GA drawing.



CAUTION!

Never use concrete anchor bolts on a cinderblock or brick wall! (Ref. Fig. 25) The wall will not withstand the pull force developed by the lift. Use only recommended anchoring and bracing methods illustrated in this manual. Equipment damage or personal injury could result.

2. Add side bracing as necessary for your particular installation in order to prevent the beams from flexing or swaying sideways during operation.
3. Weld additional mast cross bracing to keep mast beams from spreading, quantity depends on travel (refer to GA drawing). Take necessary precautions to minimize beam movement resulting from the heating & cooling of welds. Re-check and confirm guide angle dimension.

DIAGONAL BRACING (when used)

4. Install upper and lower diagonal bracing per the GA drawing for your installation in order to prevent bowing of the beams during operation.

INSTALLATION INSTRUCTIONS



WARNING!

Do not weld on the guide flanges of the masts. The field welding of any structural steel member into or across the guide beams in the path of the wheel guides is strictly forbidden. Interfering with the free travel of the wheel guides could create severe structural damage or cause the lifting chains to over-stress and fail resulting in permanent lift damage and/or severe injury to personnel

INSTALLATION INSTRUCTIONS

ANCHORING TO BLOCK WALLS

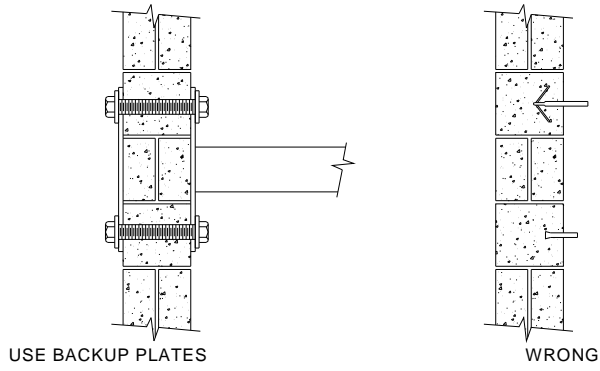

WELD TO CURB ANGLE

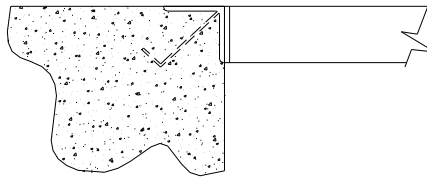

ANCHORING TO FACE OF FLOOR

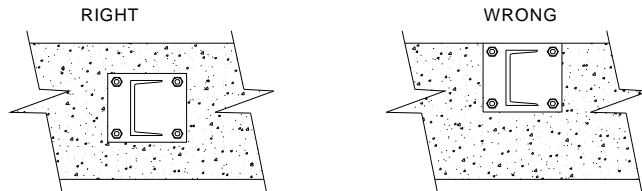

WOODEN FLOORS

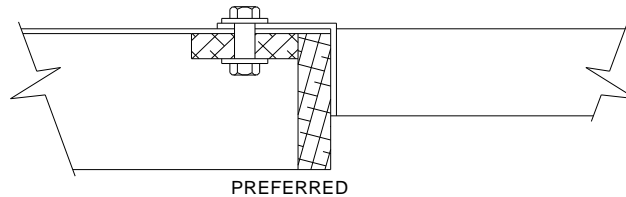

PREFERRED

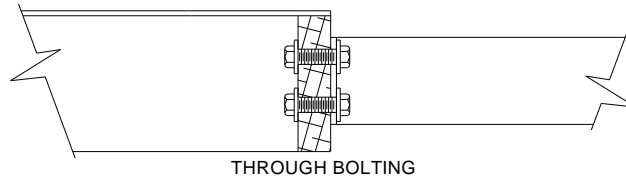

THROUGH BOLTING

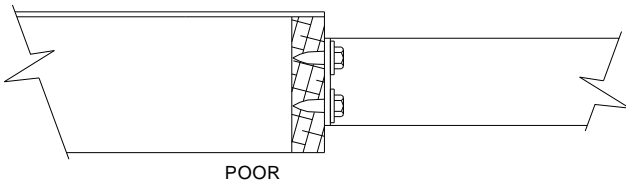

POOR

Figure 25 Approved Methods for Upper Level Mast Bracing

INSTALLATION INSTRUCTIONS

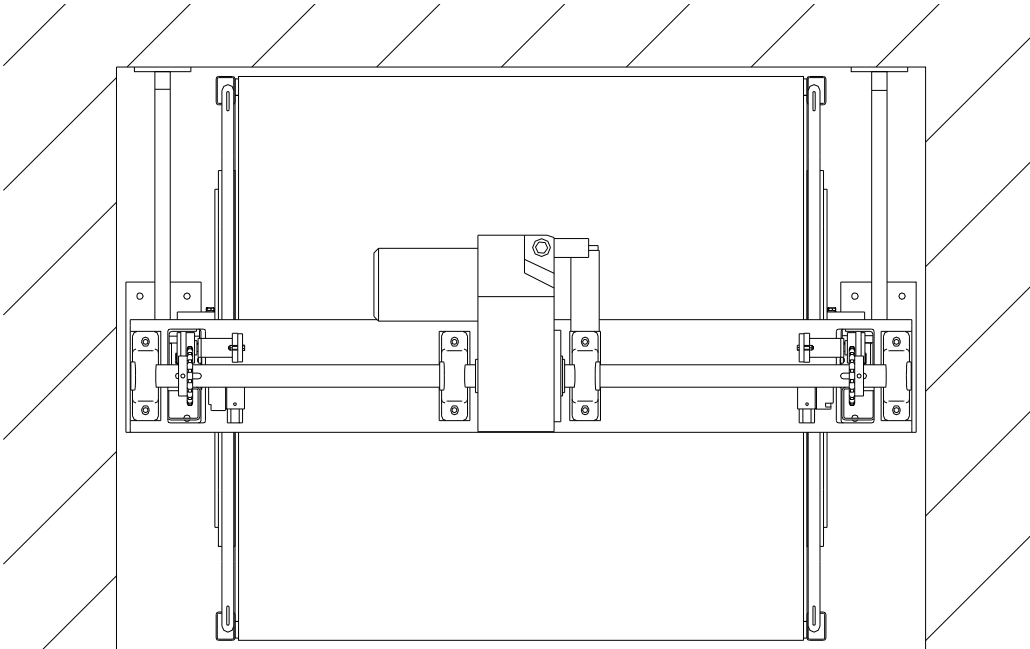

THROUGH CUT-OUT OR OVER-SIZED HOLE

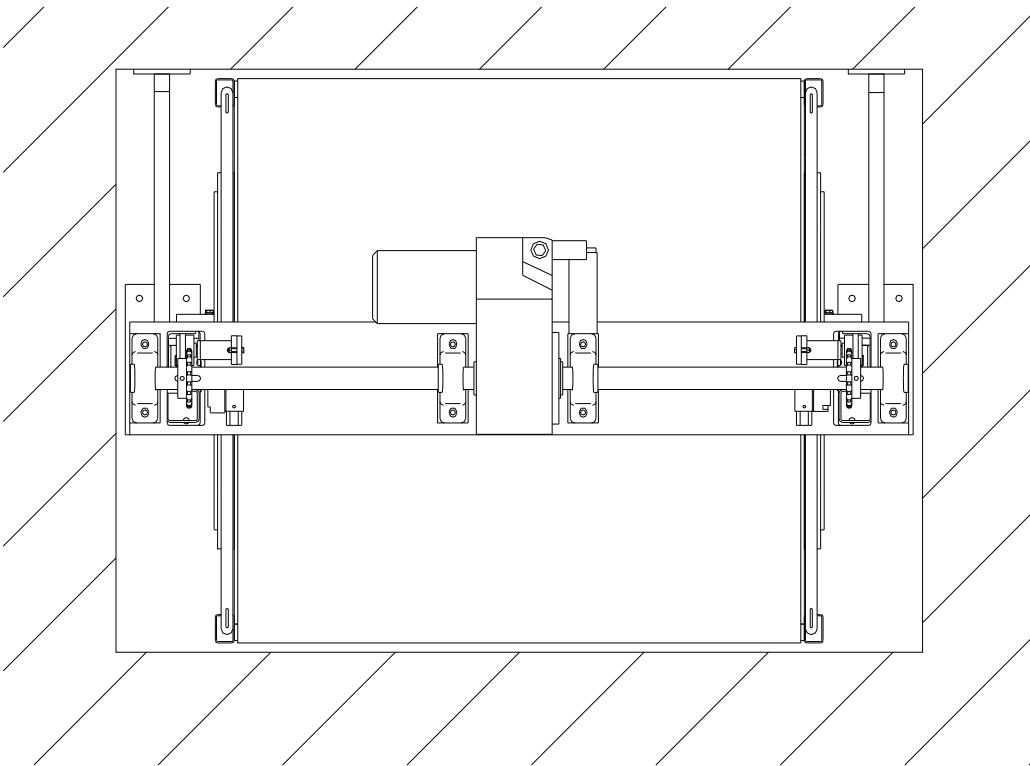

THROUGH FLOOR

Figure 25 (cont'd) Approved Methods for Lower Level & Diagonal Bracing

INSTALLATION INSTRUCTIONS

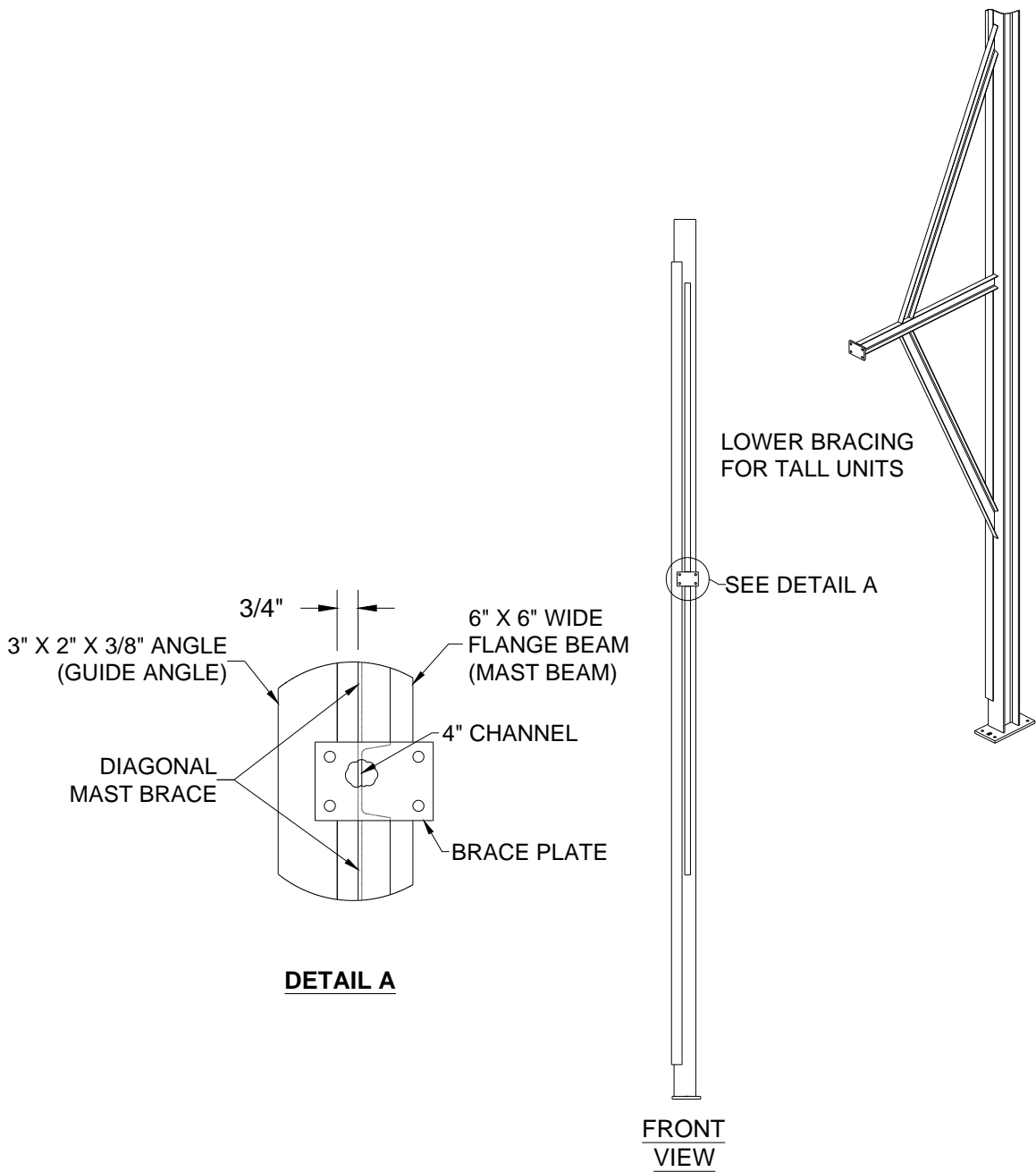
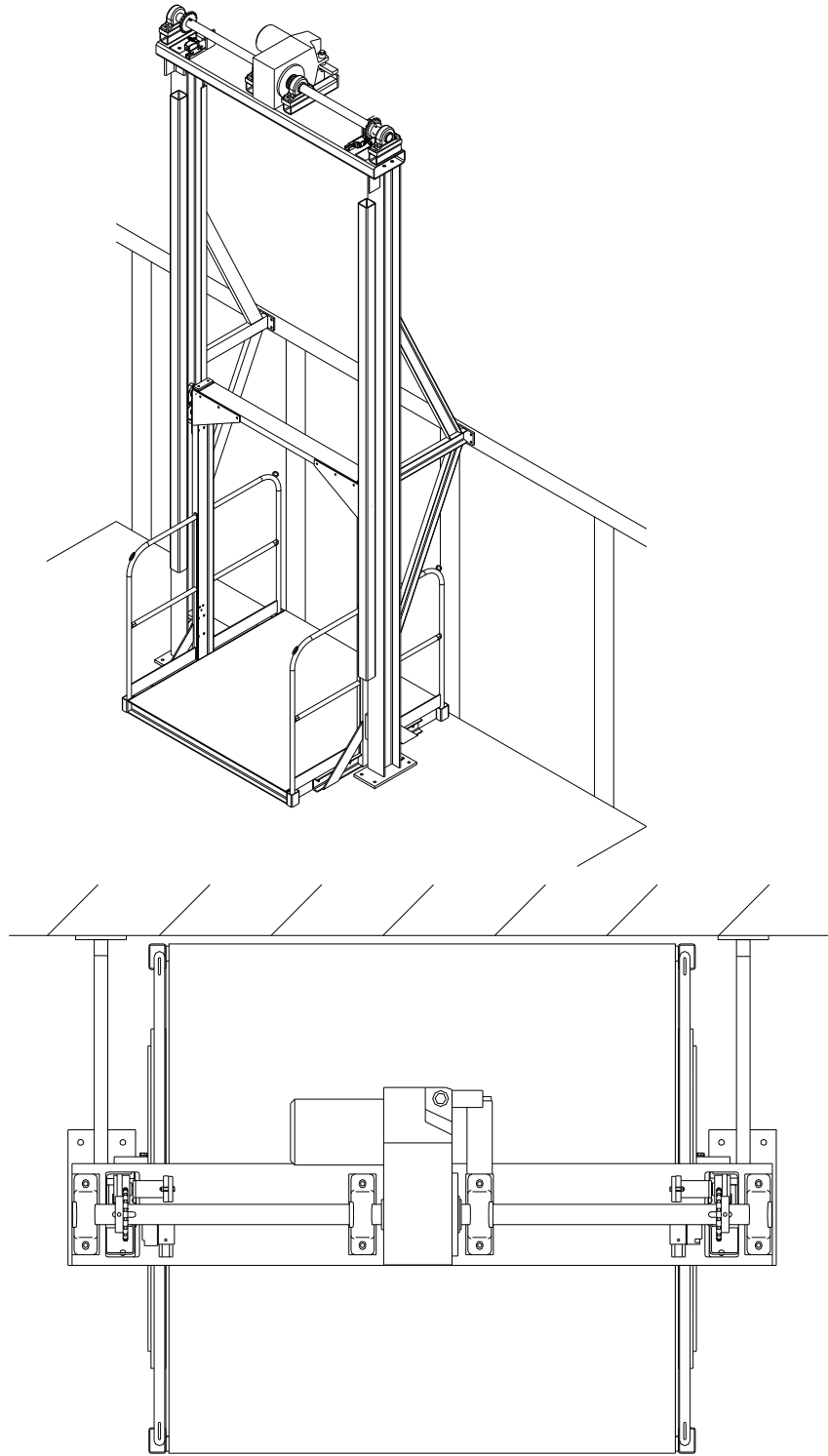

Figure 25(cont'd) Approved Methods for Lower Level & Diagonal Bracing

INSTALLATION INSTRUCTIONS



EDGE OF MEZZANINE

Figure 25 (cont'd) Approved Methods for Lower Level & Diagonal Bracing

INSTALLATION INSTRUCTIONS

G. LIFTING CHAIN INSTALLATION DETAILS (Reference Figures 26 through 28)

Items needed:

<u>Qty</u>	<u>Description</u>
2	Lifting Chains
2	Counterweights
2	Lifting Chain Master Link Assemblies

1. Familiarize yourself with the drive base layout on top of the lift, ensure that all components are present and oriented as shown in **Figure 24**.
2. Find the two (2) equal lengths of lifting chain, lay out on a clean surface.
3. Raise each chain up to the drive base, lower one end of the chain down the mast beam to the carriage upright and wheel guides. Lay the other end up and over the sprocket on the top of each mast as shown in **Figure 26**.
4. Make sure that the carriage is level at the lower level before connecting one end of the lifting chain to the wheel guide with the hardware listed & provided as shown in **Figure 27a and b**.
5. With all chains in place, make sure that each of the chains have the equal number of links to the top of sprocket & that they are equally tight by lifting them over each drive sprocket and the free end down into its respective counterweight tubes.
6. Break the free end of each chain at 12-13 inches below each sprocket (again, with the carriage resting on the ground).
7. Using the hardware provided, attach a counterweight to the end of each chain as shown in **Figure 28**.
8. Slide each counterweight into its guide tube.

When complete, the lifting chain path should look like that shown in **Figure 26**.

INSTALLATION INSTRUCTIONS

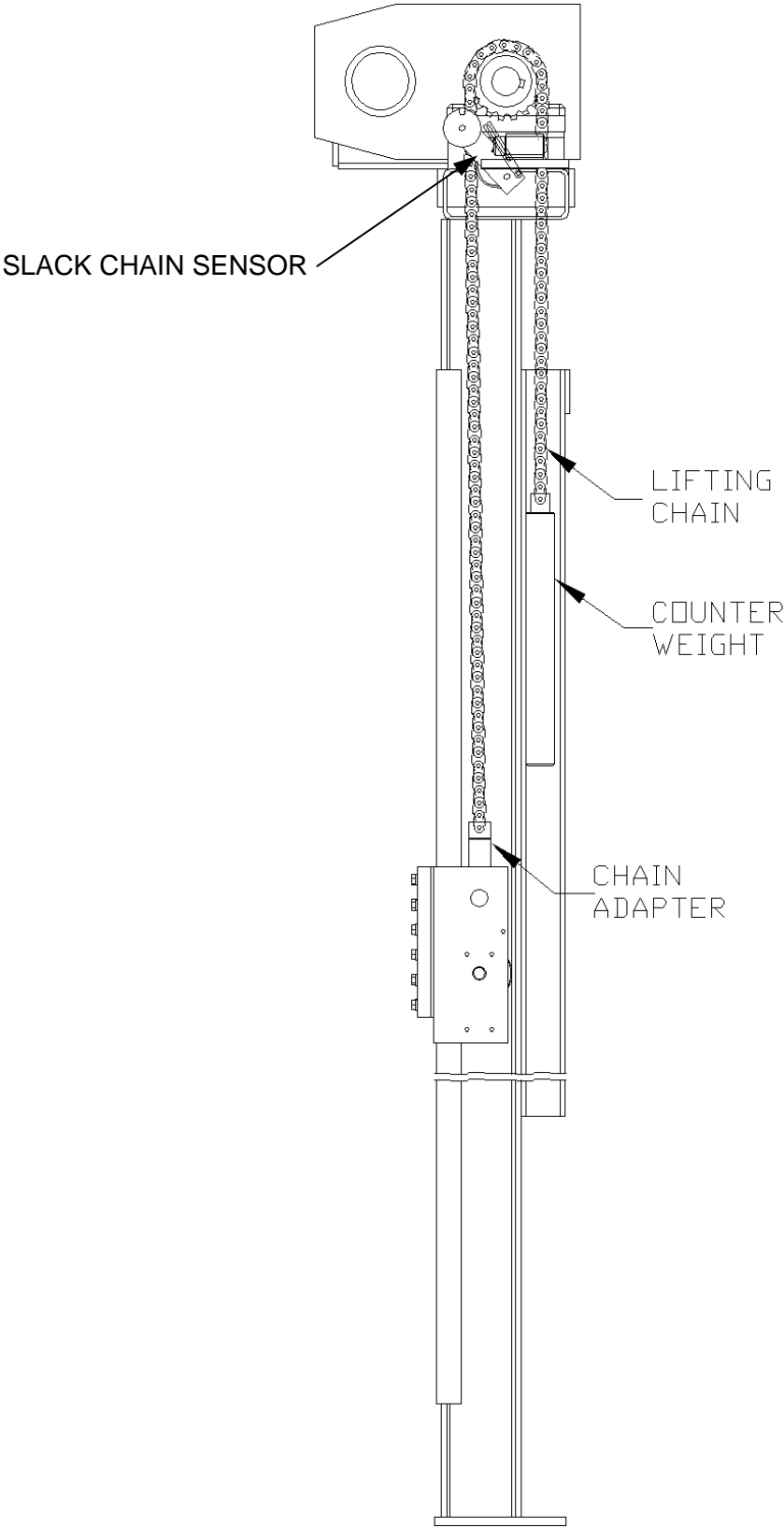

Figure 26 Lifting Chain Path

INSTALLATION INSTRUCTIONS

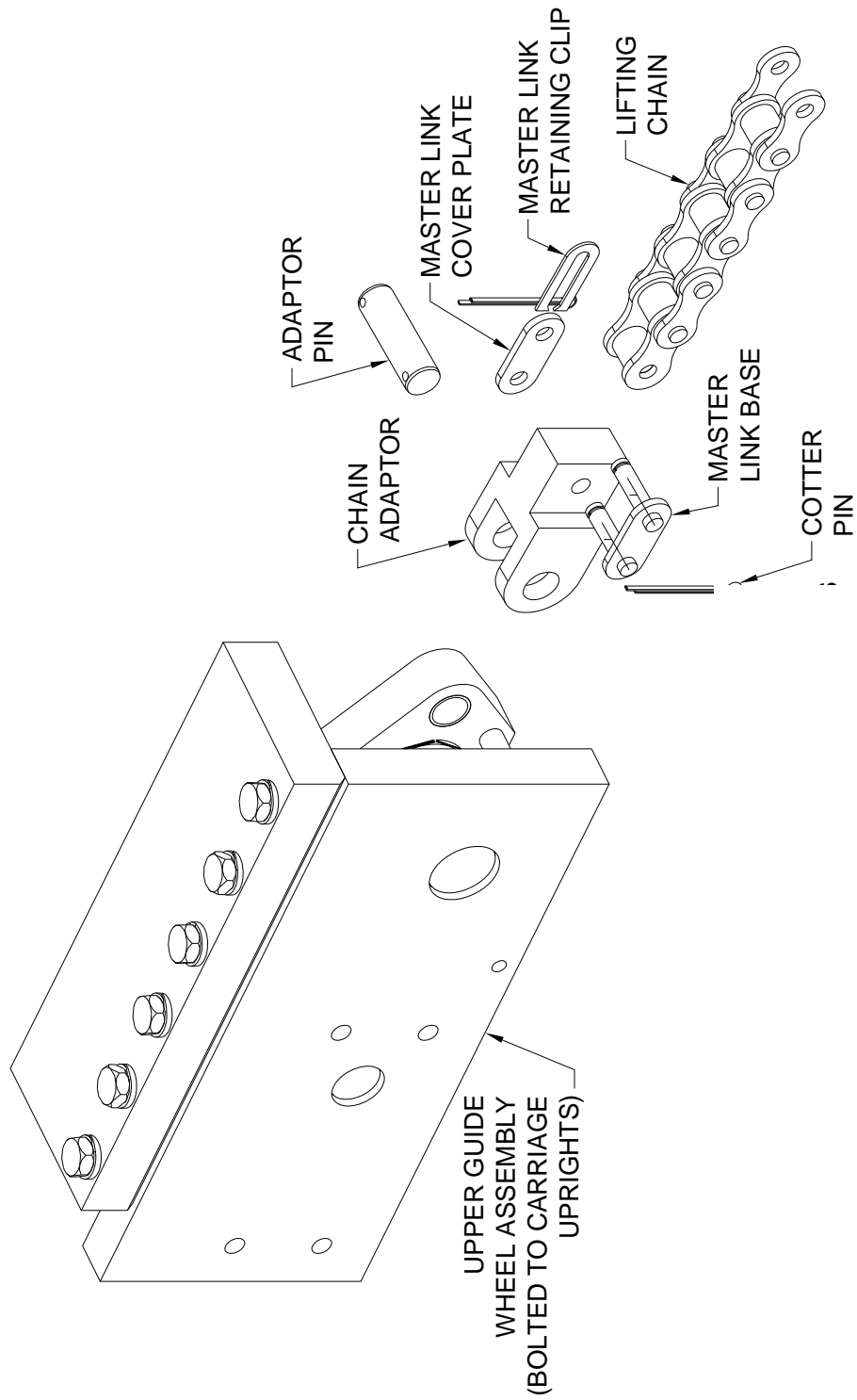

Figure 27a Locking Cam Attachment

INSTALLATION INSTRUCTIONS

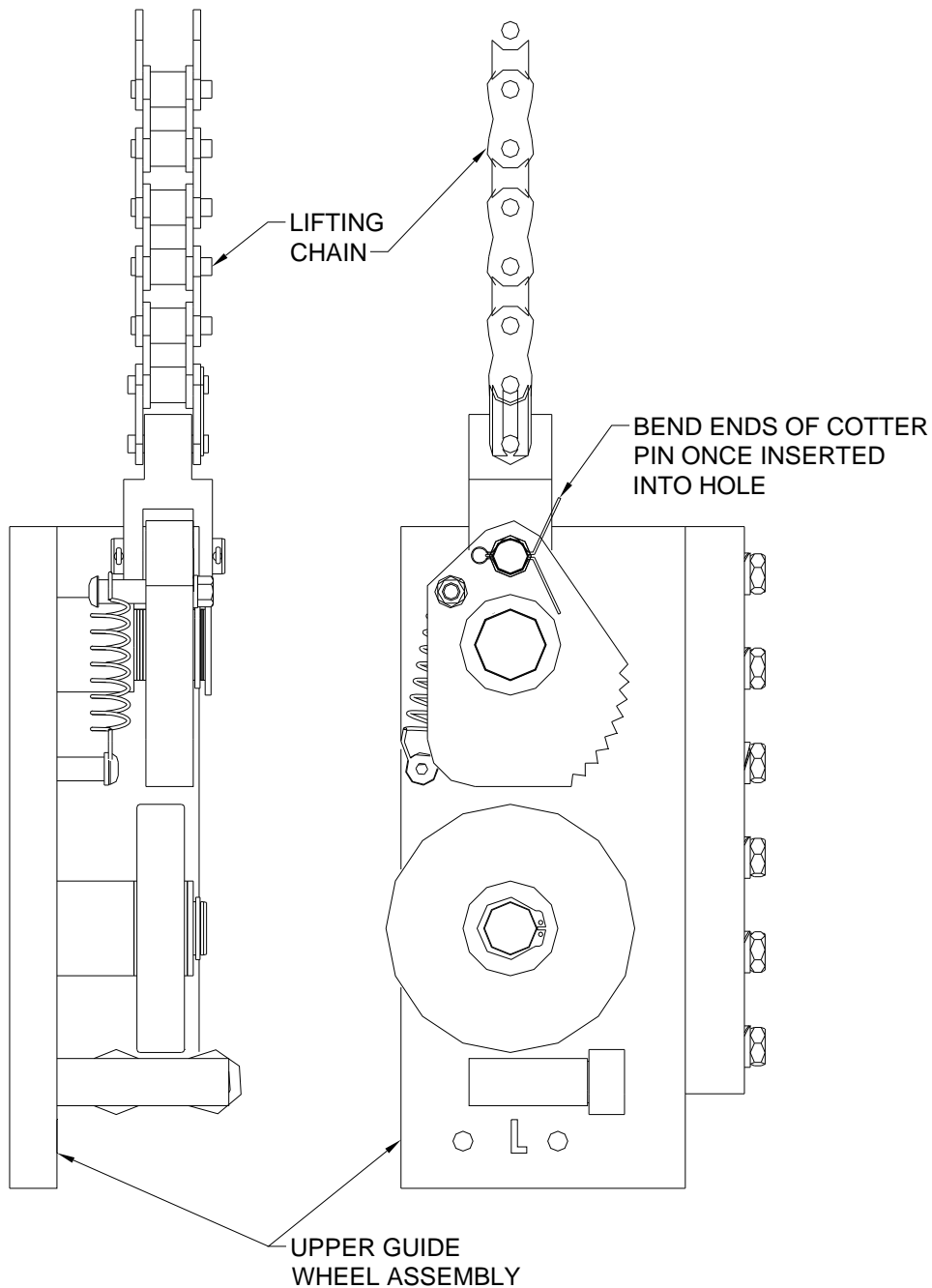

Figure 27b Locking Cam Attachment

INSTALLATION INSTRUCTIONS

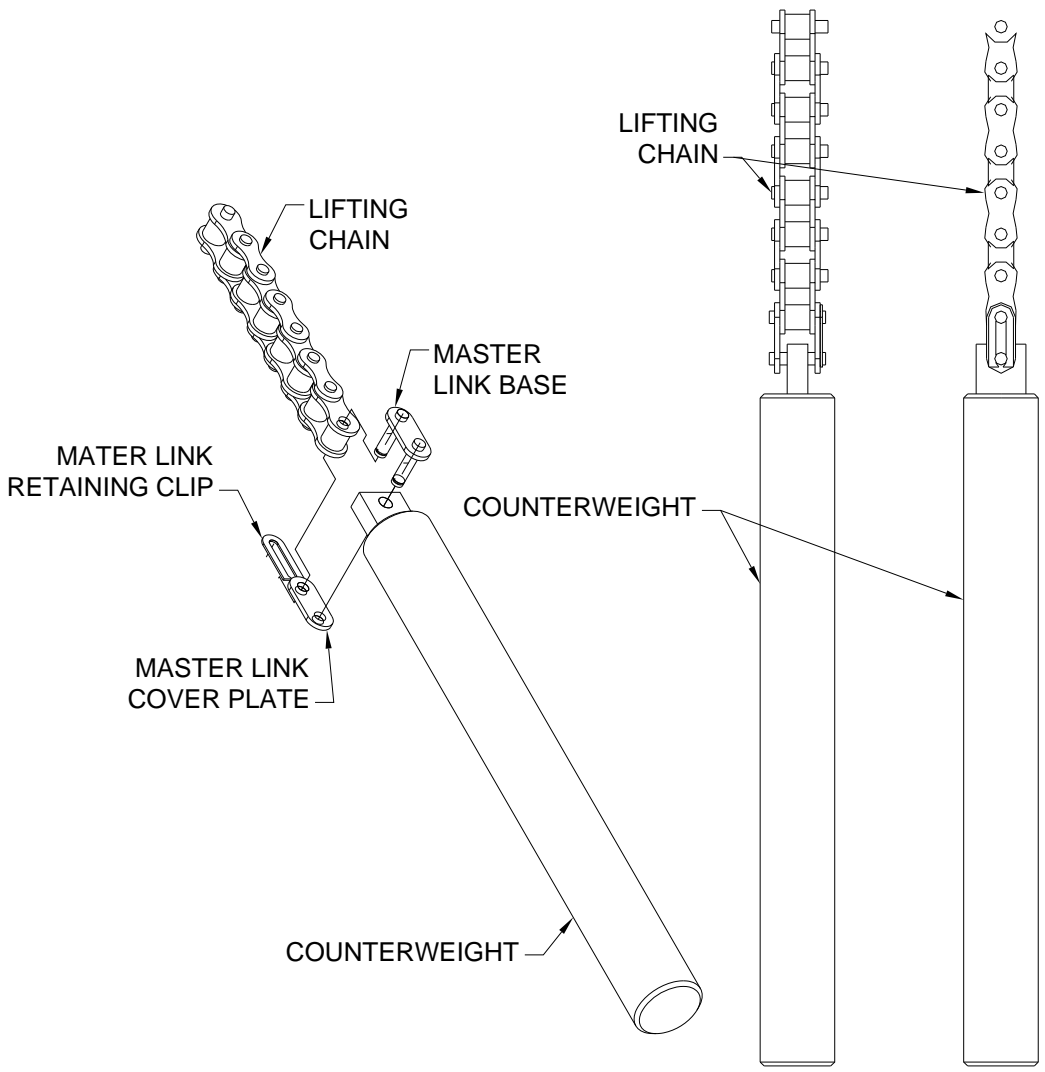

Figure 28 Counterweight Connection

INSTALLATION INSTRUCTIONS

H. WIRING THE EURODRIVE BRAKE MOTOR

EURODRIVE gear motors are designed and manufactured with totally enclosed, fan-cooled, squirrel-cage induction motors which are designed for operation under difficult conditions. The windings are protected with a special insulating material Class B equivalent or better. The brake motors incorporate a DC disc brake, and the supply is taken from a half-wave rectifier mounted inside the motor terminal box and an SR relay mounted on the motor terminal box which switches DC power on and off.

1. Voltage to the rectifier energizes the brake coil and releases the brake.
2. Removal of the voltage to the brake de-energizes the brake coil and allows the brake to be applied.
3. The SR relay is to switch the DC voltage to brake coil shortening brake response time.
4. The AC voltage to the brake will be rectified to a DC level of 50% of the AC voltage applied.
5. For a standard 230/460-volt 3-phase motor, 230/460 volt single-phase must be provided to the rectifier from the motor terminals.

The voltage to the brake must be applied and removed at the same time as the power to the motor. When the lift stops, three things must happen:

- Power must be removed from the motor.
- The AC line to the rectifier must be broken.
- A jumper line across two of the rectifier terminals must be broken.

NOTE: The brake action will be slow and inconsistent if these three conditions are not met.

Remember, rotation of a 3-phase motor may be reversed by reversing the connections of any two motor electrical leads.

INSTALLATION INSTRUCTIONS

I. LEVELING CARRIAGE



WARNING!

When running the unit before ALL limit switches are installed, be prepared to disconnect power on demand. Allowing carriage over-travel in either direction can result in severe damage to the equipment and potential injury to standers-by. Temporary power must NOT be used.

1. Make sure the carriage is free to rise about six (6) inches. Check to be sure carriage is level and chains are equally tight.
2. Continue to raise carriage in small six (6) inch increments, checking for binding or interference. Make any changes necessary to align beams to allow smooth travel.
3. Stop carriage at the upper level and check to make sure it is level and that there are the same number of chain links between the wheel guides & lifting sprockets. DO NOT attempt to tighten or loosen chain with the carriage in the raised position.
4. Lower the carriage in small increments. Watch again for adequate clearance throughout the travel, checking for interference or binding of the chain and carriage.



CAUTION!

All chains must be fully engaged with the teeth of all chain sprockets before operation begins. Chains which jump the sprockets during tensioning can cause permanent damage to the lift

INSTALLATION INSTRUCTIONS

J. INSTALLING LEVEL/OVER-TRAVEL LIMIT SWITCHES (Ref. Figures 29 to 32)

Items needed:

<u>Qty</u>	<u>Description</u>
Varies	Level Limit Switch Kits
1	Over-Travel Limit Switch Kit
1	Maintained Contact Limit Switch Kit (mid-level on 3-level applications only)



DANGER!

Never go under a platform! To avoid personal injury or death, be sure the platform has been blocked from underneath! See “Blocking Instructions.”

LEVEL LIMIT SWITCHES (Fig. 29)

Level limit switch Kits (quantity depends on application – typically one per level), including field-located cam strikes, have been shipped loose to be field mounted, wired, and adjusted to sense the status/position of the lift carriage.

1. Locate & weld the limit switch cam striker assembly to the top of the 48” carriage side guard or hand rail in the orientation & location shown.
2. Find & assemble the adjustable limit switch kits as shown, including the Unistrut mounting channel (**Fig. 31**).
3. Once assembled, orientate and field weld the Unistrut channels in such a way as to allow the limit switch arm to make contact with the limit switch cam when the carriage is at that corresponding level – leaving room for adjustment.
4. For best results in adjusting position of the switch, loosen the mounting bolts that hold the switch to the Unistrut channel just enough so that the switch can be lightly “tapped” into position.

NOTE: To change the actuation direction of the switch, remove the switch head. Change the actuating control knob/mechanism to the desired actuation direction. (Reference **Figure 32**)

OVER-TRAVEL LIMIT SWITCH (Fig. 30)

1. Find & assemble the adjustable limit switch kit as shown, including the Unistrut mounting channel (**Fig.31**).
2. Locate and weld the Over-travel limit switch approximately 6” above the top level limit switch kit and adjust position per steps 3 & 4 above.

NOTE: You will have to temporarily remove the upper level switch arm to be able to travel past the upper level switch to the over-travel switch. Replace when done.

INSTALLATION INSTRUCTIONS

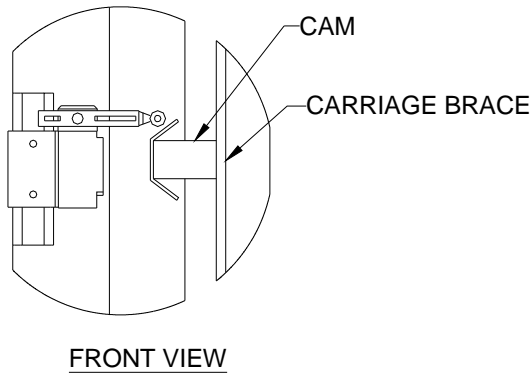
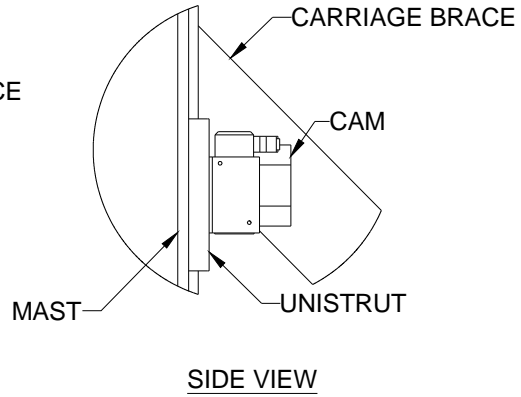
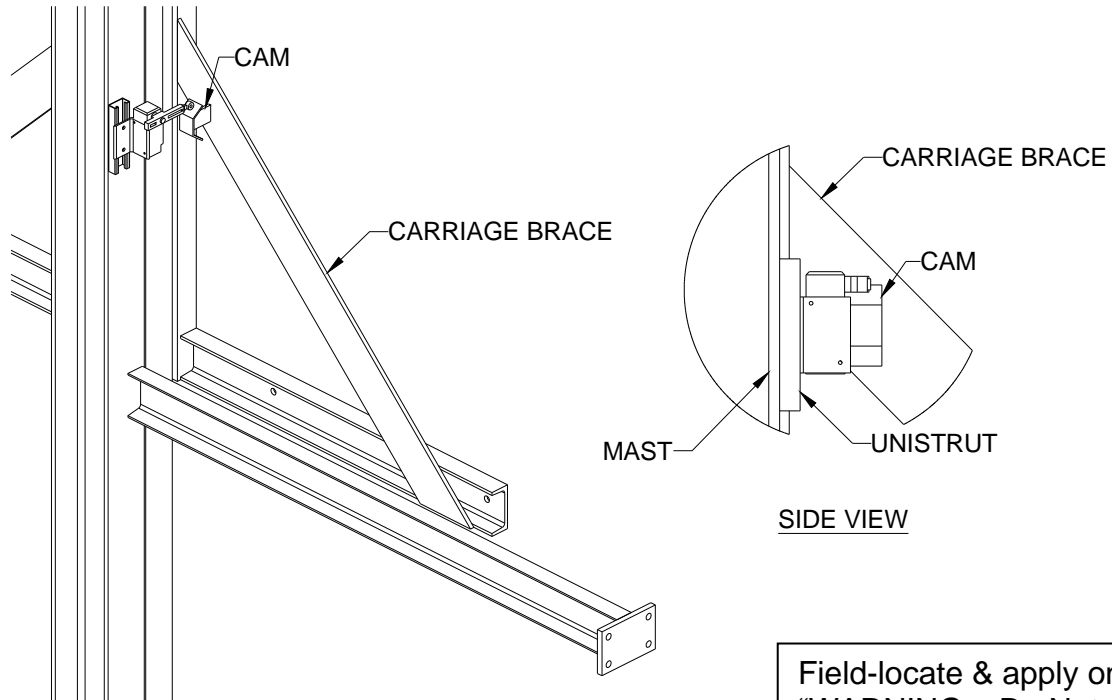

Field-locate & apply one "WARNING – Do Not Tamper" label adjacent to (within 6"-12") each sensing device (limit switches, door status switches, door interlocks, etc.) in a location that is visible to the operator.

▲ WARNING
Do NOT tamper or interfere with this device. Serious injury can result.

(Actual Size 1" x 2")

Figure 29 Level Status Switch Location

INSTALLATION INSTRUCTIONS

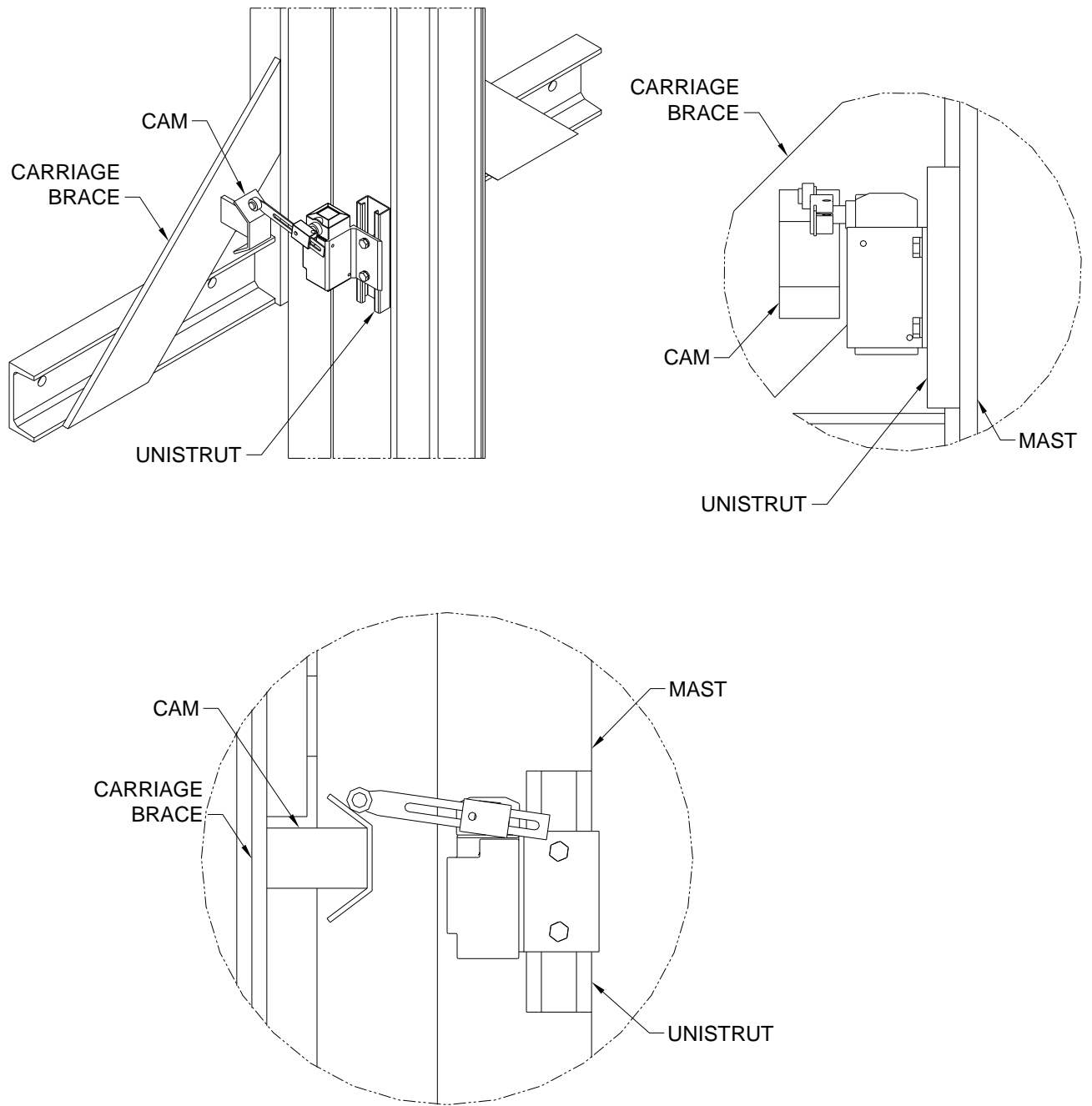

Figure 30 Over-Travel Switch Location

INSTALLATION INSTRUCTIONS

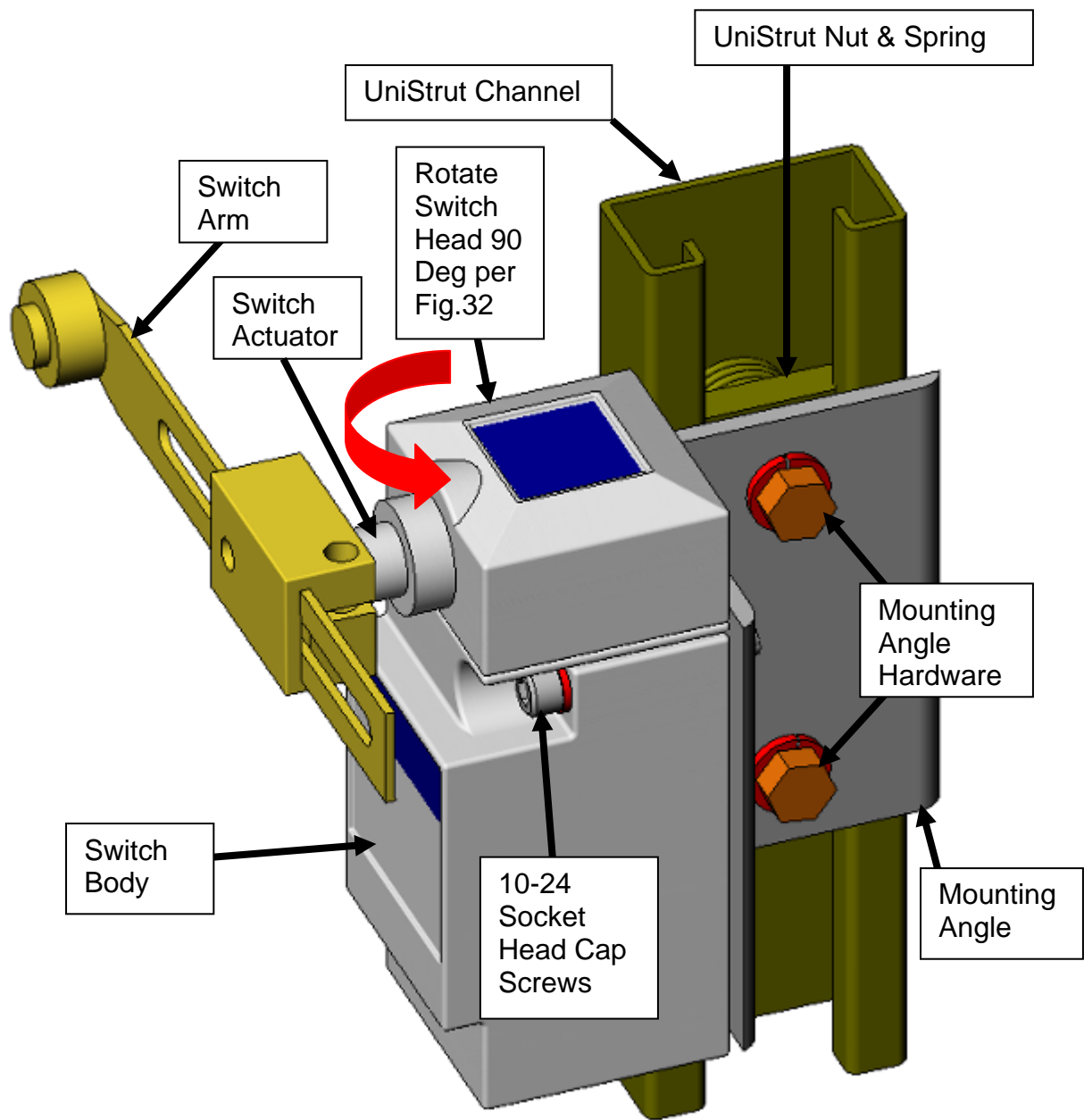

Figure 31 Level Limit Switch Kit Assembly

INSTALLATION INSTRUCTIONS

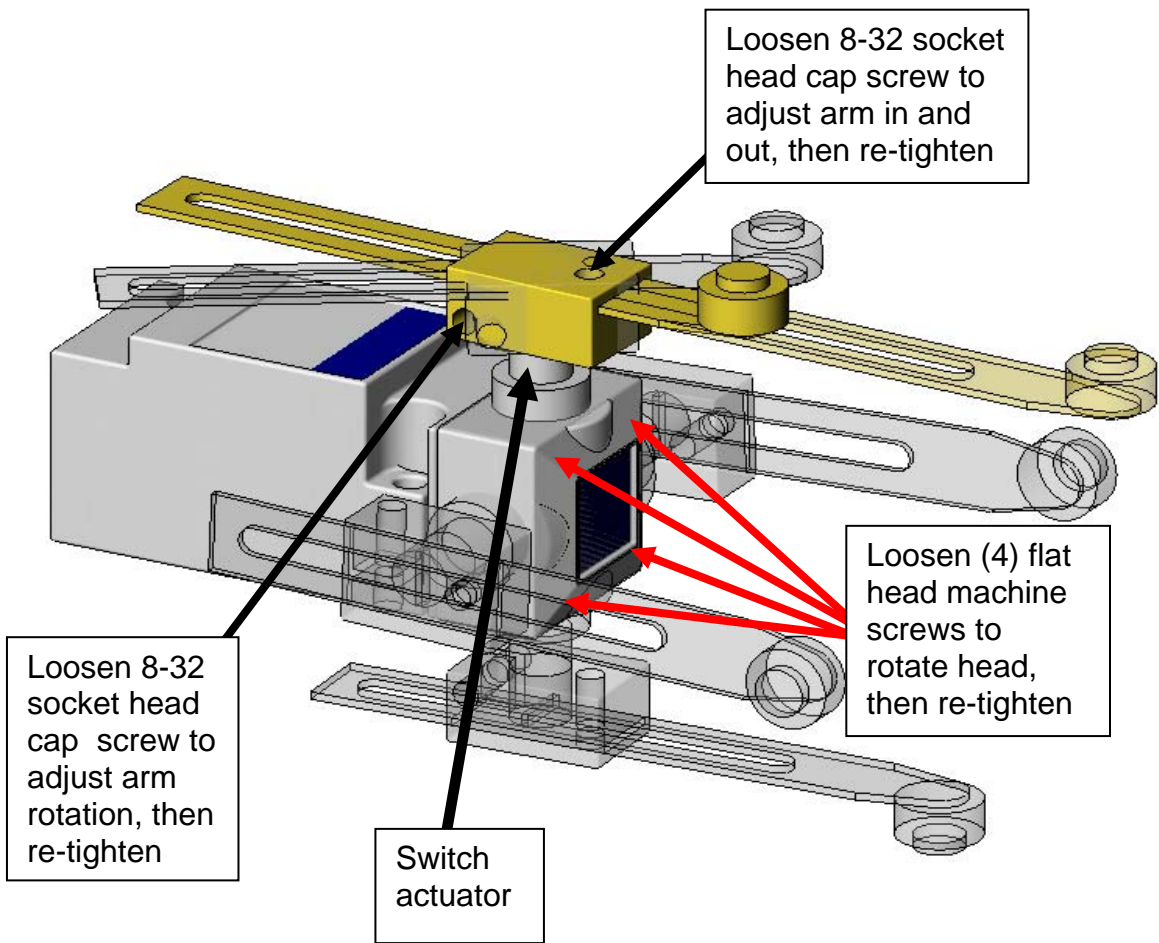

Figure 32 Sensing Switch Adjustments

INSTALLATION INSTRUCTIONS

K. INSTALLING SLACK CHAIN SENSING SWITCHES (Ref. Figures 33a & 33b)

Items needed:

<u>Qty</u>	<u>Description</u>
2	Slack Chain Sensing Switch Kit

These kits have been shipped loose to be field mounted, wired, and adjusted per the procedure below. These switches are intended to turn off the motor and stop movement of the carriage whenever a slack/broken chain status is sensed.



DANGER!

To avoid personal injury or death, the procedures described in this section should only be performed by qualified service personnel.

1. To install the slack chain sensing switches, first gain a safe access to the drive base at the top of the masts. There is a slack chain sensing switch kit provided for each lifting chain, (2) total.
2. With the carriage hanging from the chains, each tensioner arm will be pushing towards the sensing switch arm. Each switch is wired to be normally open – held closed.
 - a. Install each switch assembly onto its respective Unistrut channel as shown in **Figure 33a**.
 - b. With the sensing switch arm mounted hanging down & tightened, slide the sensing switch assembly in the Unistrut channel towards the tensioner arm until the switch arm pushes against the tensioner arm and the switches electrical contacts close (listen for the “click”). **See Fig. 33b**.
 - c. Tighten the two bolts holding the switch mounting angle to the Unistrut.

NOTE: To change the actuation direction of the switch, remove the switch head. Change the actuating control knob/mechanism to the desired actuation direction. (Reference **Figure 32**)

3. After installing the slack chain sensing switches, you must test them to make sure they are adjusted and set correctly.
 - a. stack some empty pallets under the carriage, surface must be level
 - b. operate the lift and lower the empty carriage onto the pallets
 - c. when the carriage makes contact with the pallets and as soon as the lifting chains go slack, the motor should stop.

CAUTION: Be ready to press the emergency stop button if the motor doesn't stop when chains go slack.

INSTALLATION INSTRUCTIONS

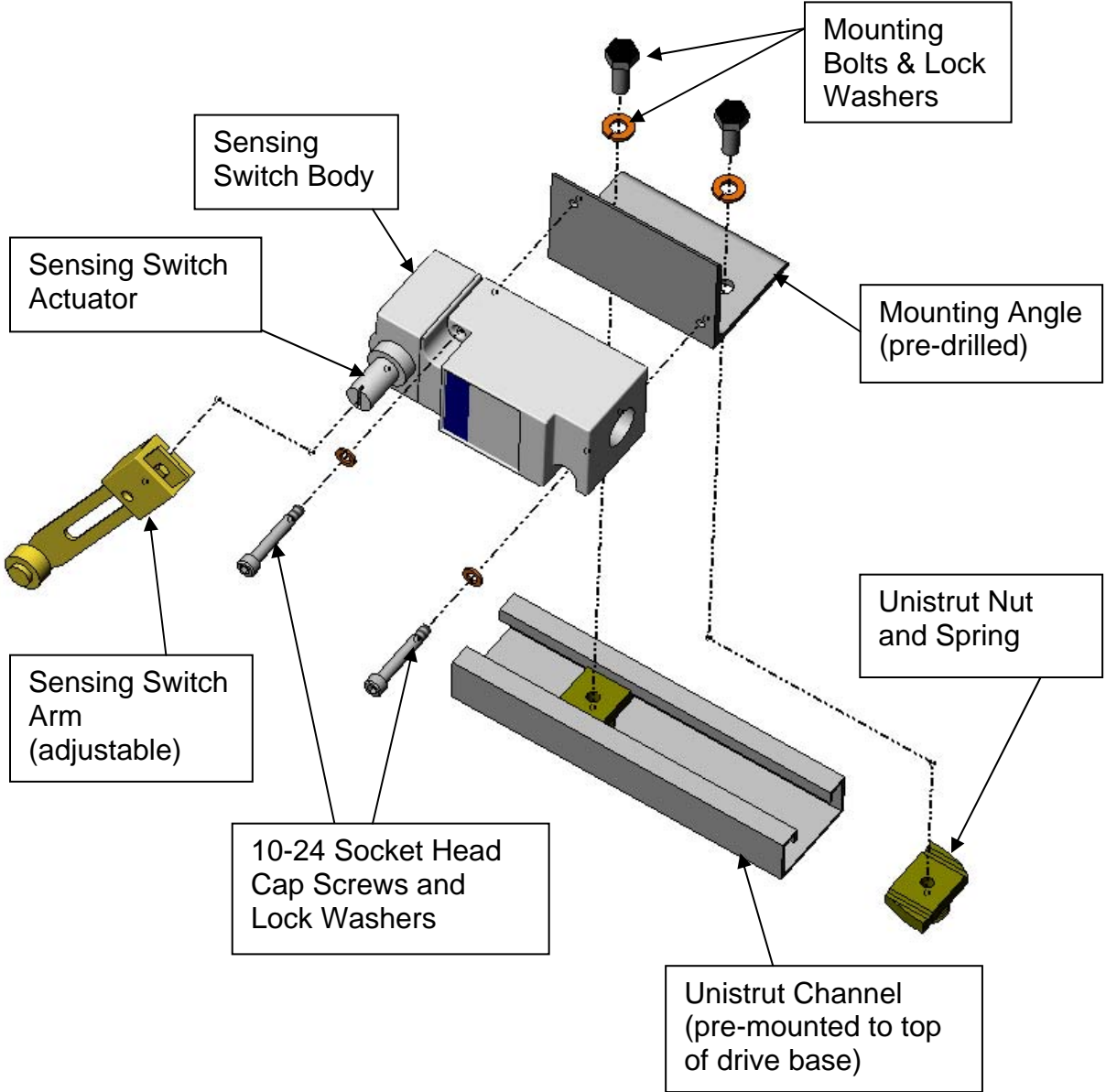

Figure 33a Slack Chain Sensor Kit Assembly

INSTALLATION INSTRUCTIONS

IF THE MOTOR STOPS WHEN CHAINS GO SLACK

4. A qualified electrician should, while referencing the lift's electrical schematic, test the electrical continuity of both slack chain sensing switches inside the lift's motor control panel to make sure that the contacts in both switches are in the open condition. If both are confirmed open, proceed to step 7. If either switch has contacts which test closed, repeat steps 2 through 5.

IF THE MOTOR DOESN'T STOP WHEN CHAINS GO SLACK

5. If the emergency stop button had to be used to stop the motor, repeat steps 2 through 5 to further adjust & re-test both slack chain sensing switches.
6. Once confirmed that both slack chain sensing switches are in the open condition as required, chain tension must be re-established in both lifting chains. However, because the slack chain sensing switches are now set properly, the motor will not run to lift the chains. Therefore, a qualified electrician must install a temporary wire jumper inside the lift's motor control panel and bypass the slack chain sensing switches in order to be able to run the motor and raise the carriage enough to re-establish chain tension. Refer to the job-specific electrical schematic for identification of the correct electrical contacts to accomplish this.

NOTE: Make sure to remove the temporary jumper once the sensors are adjusted properly and after chain tension is re-established in both lifting chains.

Should you have any questions or need assistance please call Autoquip Product Support (888-811-9876).

INSTALLATION INSTRUCTIONS

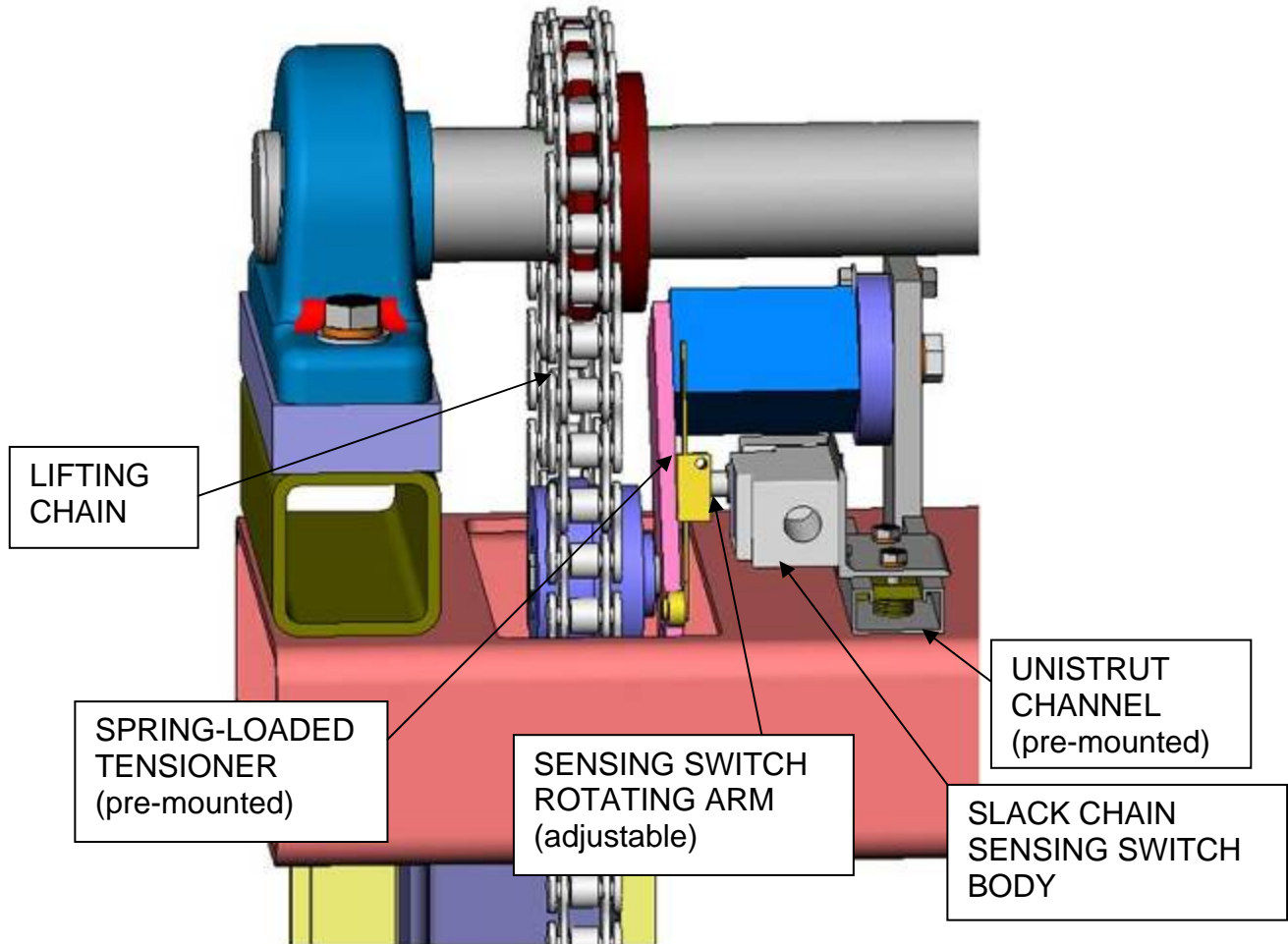

Figure 33b Slack Chain Sensor Kit Mounting

INSTALLATION INSTRUCTIONS

L. INSTALLING COUNTERWEIGHT SENSING SWITCH (Reference Figure 34)

Items needed:

<u>Qty</u>	<u>Description</u>
1	Counterweight Sensing Switch Kit

This kit has been shipped loose to be field mounted, wired, and adjusted per the procedure below. These switches are intended to turn off the motor whenever a counterweight attempts to come out the top of its guide tube during lift operation.

1. To install the counterweight sensing switch, first gain safe access to the top of the masts. There is one (1) counterweight sensing switch mounting plate located on one of the two mast beams near the top as shown.
2. Assemble the sensing switch as shown, the switch is to be wired normally closed – help open.
 - a. Mount the switch body to the pre-drilled mounting plate using the hardware provided
 - b. Mount the switch arm to the switch body, sliding and rotating the switch arm so that it is positioned over the counterweight tube as illustrated
 - c. Tighten the switch arm, rotate upwards and confirm that the switch contacts open (listen for “click”) at 20 10-20 degrees of rotation. Adjust as necessary

NOTE: To change the actuation direction of the switch, remove the switch head. Change the actuating control knob/mechanism to the desired actuation direction. (Reference Figure 32)

3. Ensure that the counterweight will in fact make contact with the switch arm as the counterweight is pulled out the top of the square tube.
4. After installing the sensing switch, it should be tested to make sure it is adjusted and set correctly. A qualified electrician should, while referencing the lift’s electrical schematic, test the electrical continuity of the sensing switch inside the lift’s motor control panel to make sure that:
 - a. the contacts in the switch are in the closed condition when in the running position (normal, “home” position)
 - b. The contacts in the switch are in the open condition when in the activated/rotated position (switch arm must be rotated manually & held up during testing)

INSTALLATION INSTRUCTIONS

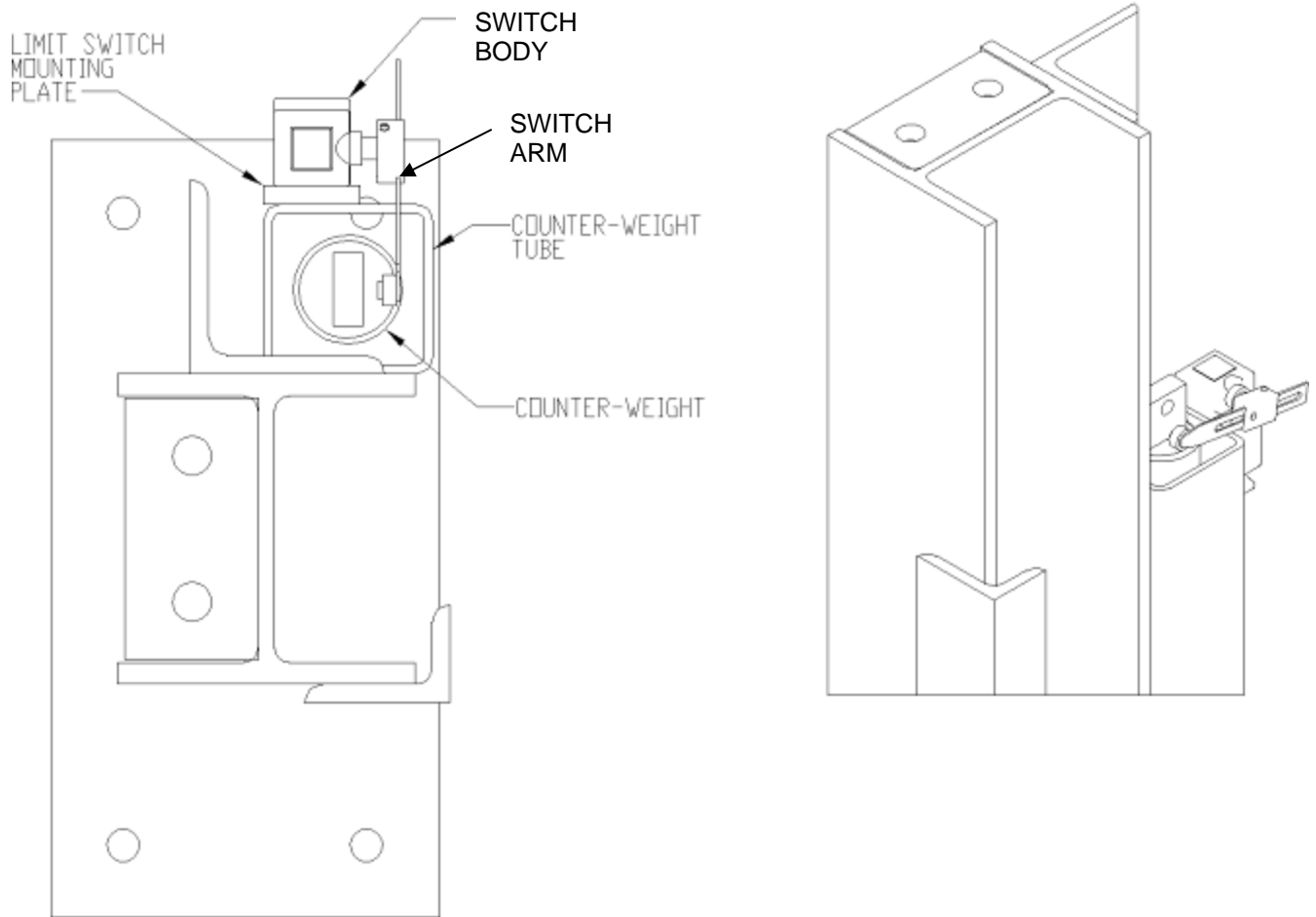

Figure 34 Counterweight Sensing Switch Location

INSTALLATION INSTRUCTIONS

M. TEST RUN (EMPTY) & MAKE ADJUSTMENTS



DANGER!

Never go under a platform! To avoid personal injury or death, be sure the platform has been blocked from underneath! See “Blocking Instructions.”



WARNING!

Never operate the lift by “manualling” the electrical controls (using the contactors located inside the control panel). All safety devices are bypassed in this mode of operation and lift damage or severe personal injury could occur.

NOTE: Because the lift is equipped with Call-Send style operator pushbutton stations at the landings, you will have to press the red Emergency Stop button in order to stop the lift carriage in mid-travel (UP or DOWN).

1. Check that all chains and sprockets are in place and secure on drive axle and carriage. Ensure that slack chain sensing switches are in place and adjusted correctly per procedure.
2. Turn on power and press the UP button to raise the carriage 6-12” (you must press E-Stop button to stop the lift) and check for:
 - a. Correct rotation/direction of the motor
 - b. running clearance of the carriage in the guides
 - c. any unexpected noise, vibration, rubbing, interferences, etc.
 - d. proper running & alignment of chains, counterweights, etc.
 - e. level carriage deck surface



CAUTION!

All chains must make contact with the running surface of the sprockets before operation begins. Chains that are misaligned with, and come off of, the sprockets during tensioning can cause permanent damage to the lift.

3. Re-set the E-Stop button and press the DOWN push button and lower the lift. Is the platform carriage stopping level at the bottom landing?

INSTALLATION INSTRUCTIONS

4. Raise the Freightlift 3-6 feet (again, you must stop the lift using the E-Stop button) above the floor. Is everything okay? Any unusual noises? Are masts stable or do they need additional bracing?
5. If you are satisfied with the alignment and structural integrity of the unit, cycle the platform carriage higher & higher until the top landing is eventually reached, continuing to check the smoothness of operation. Be sure that at least 1" clearance is present between the carriage and all building structures, and other site constraints.



CAUTION!

Take extreme caution when running the unit before the over travel limit switch may be installed and adjusted properly! Lift over-travel can cause severe damage.

6. Lower the Freightlift a few feet (you must stop the lift using the E-Stop button) and bring it back up. If the carriage is above or below the floor, adjust limit switch arm as needed. Repeat for each level (**Reference Fig. 31 for adjustment**).

N. GATE & ENCLOSURE INSTALLATION

1. Install the gate and enclosures following the layout on the GA drawing provided with the enclosure package and referring to the Gate & Enclosure Installation Manual that has been sent separately for this particular application.
2. All gates or doors accessing the lift must have electrical contacts and mechanical locks to prevent the lift from operating if a gate is left open. The gate should lock until the carriage is at the nearest landing. There are many variables that can affect your installation: the type of gate; the type of door; conditions unique to a specific site. One (1) to four (4) electrical sensing or signaling devices are supplied with each gate that incorporates the standard interlock design.

NOTE: If the personnel guards are not purchased from Autoquip it is the responsibility of the Owner to make sure that the personnel guards are in compliance with the requirements set forth in ASME B20.1.

INSTALLATION INSTRUCTIONS

O. SHAFTWAY BARRIER BAR KIT (for shaftway applications)

Figure 36 illustrates the contents and installation details for the shaftway barrier bar system supplied for units in 2-level shaftway applications. The barrier bar system is designed to leave (1) mid and (1) top rail across the door opening at the upper level when the carriage is called to the lower level.

P. BACK-STOP KIT (when ordered)

Figure 37 illustrates the contents and installation details for the back-stop kit. Installer must ensure that the finished distance between the edge of carriage and the inside of the back-stop panels does not exceed 2 inches.

Q. ELECTRICAL CURRENT SENSOR (ECS) with TRIP RELAY (Reference Fig.35)

The ECS works with a timed, trip delay relay, which bypasses the sensor during every motor start up. The trip delay timer is factory set for 3 seconds and is not adjustable.

The current setting of the ECS is factory set to the motor's full load amp nameplate rating for the specified voltage, but must be field adjusted for specific conditions at the installation site once all electrical control and sensing devices are wired.

NOTE: It is important that the contractor or entity overseeing the installation of this lift ensures that the electrician has made these adjustments to the ECS to prevent the lift from damaging itself under over-loading or jam-loading conditions.



DANGER!

Secure platform and chains! Do not remove or disconnect the motor or brake unless the platform and chains have been secured per “Blocking Instructions” section. Serious injury or death may result.

1. Load the carriage to the rated capacity and run the lift. Record the full load amp draw reading of the motor with the loaded carriage.
If the motor DOES shut off within approximately 3 seconds – Go to Step 2.
If the motor DOES NOT shut off during lift travel – record the full load amp reading and Go to Step 3.

INSTALLATION INSTRUCTIONS

2. Turn the power off and adjust the ECS amp rating up by turning the small amp dial on the front of the ECS in a clockwise direction. Do not increase more than 5 amps at a time. Repeat this process until the lift will raise the rated load without shutting off.
3. Once the lift will operate with the nameplate capacity on the lift carriage, add an additional 15% to the amp draw reading on the dial. Run the lift several times to make sure your setting is correct and the carriage will run full up and down without tripping ECS off. If the ECS does still trip off go back to step one and repeat setting requirements.



WARNING!

To avoid serious injury or death, **GUARDS, INTERLOCKS, and SAFETY DEVICES** must be restored to correct operation when installing parts or making repairs.

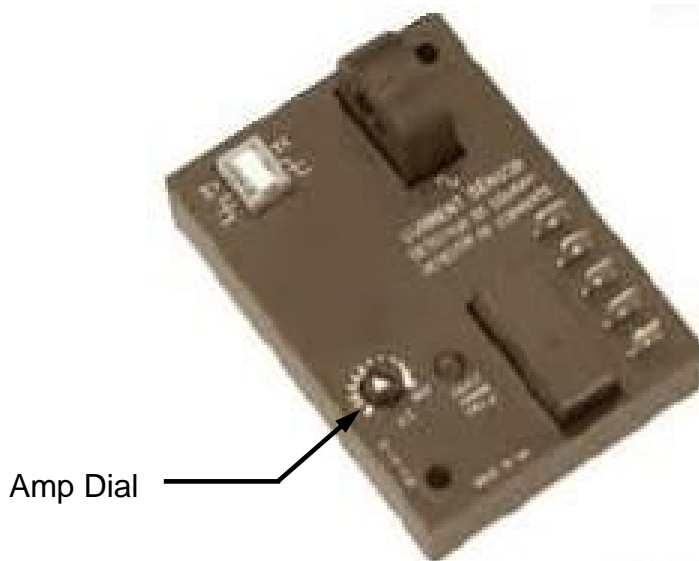

Figure 35 ECS Enclosure

INSTALLATION INSTRUCTIONS

R. INSTALLATION WRAP-UP

1. After the unit is completely wired, make all necessary and final adjustments to ensure proper operation of the lift and its safeties as required by the schematic.
2. Refer to the Inspection Checklist located in the **Appendix** of this Manual, and confirm the safe and correct condition of each component/feature listed to ensure that the lift is ready to be given to the User in proper & safe working condition. This includes, but is not limited to functionality of gate interlocks, gate status switches, lift level/status limit switches, and slack chain sensing switches.
3. Ensure that the appropriate person signs off on the Warranty Registration Card and receives one Operation & Service Manual per lift.
4. Install all WARNING SIGNS AND DECALS provided with the unit which may have been shipped loose for field installation (gate panel, etc.). Refer again to **Figure 1**.
5. Clean up the area, paint and touch-up as needed.
6. Conduct Operator training before handing off the lift to the customer. Use this manual as reference for this training & familiarization process.

INSTALLATION INSTRUCTIONS

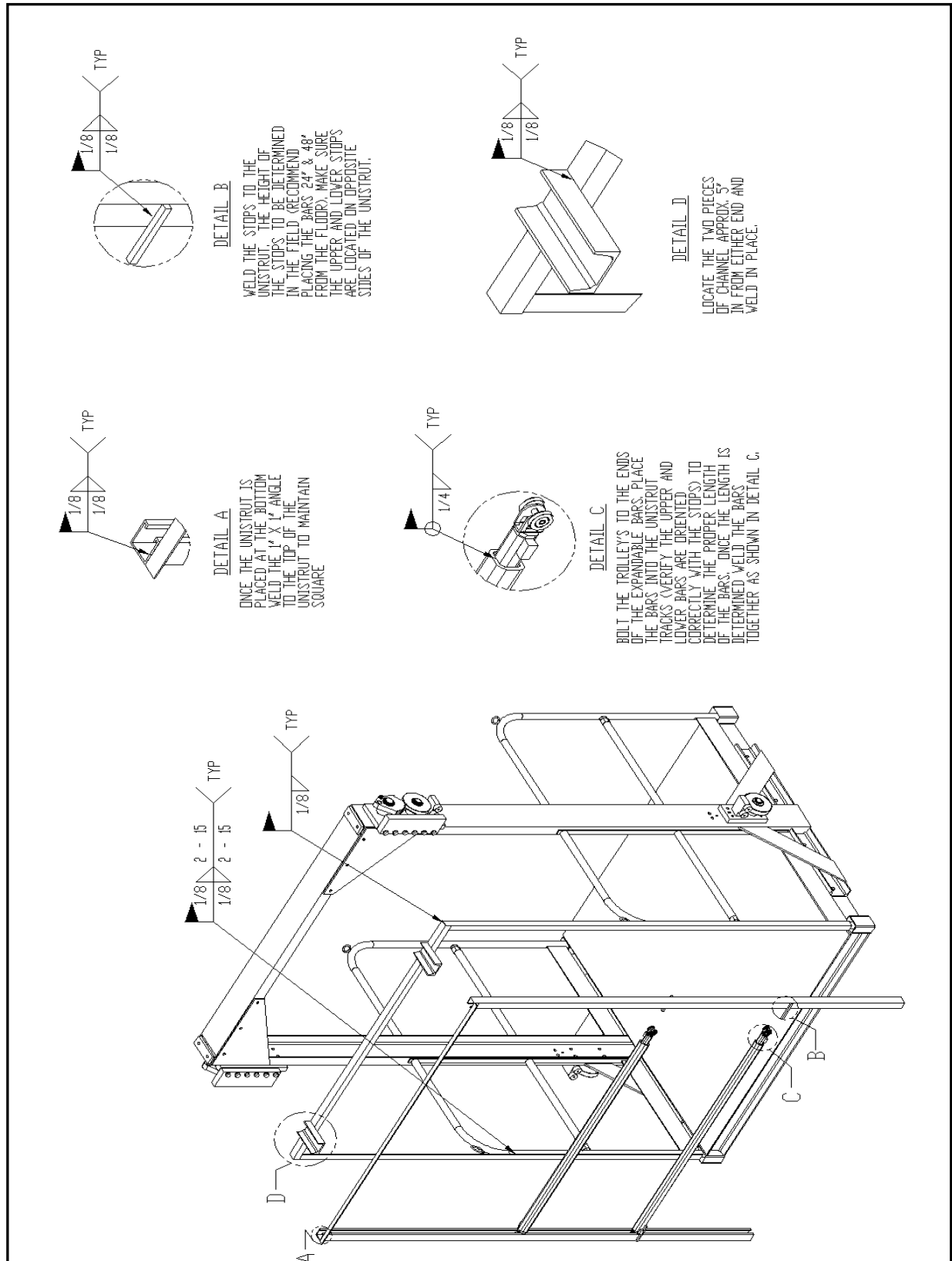

Figure 36 Barrier Bar Installation Details (when required)

INSTALLATION INSTRUCTIONS

- ① 2" x 1-1/2" ANGLE, 48" LG, 1 PC.
- ② 2" x 1" CHANNEL, 78" LG, 4 PCS.
- ③ 2" x 1/4" BAR, 156" LG, 2 PCS.

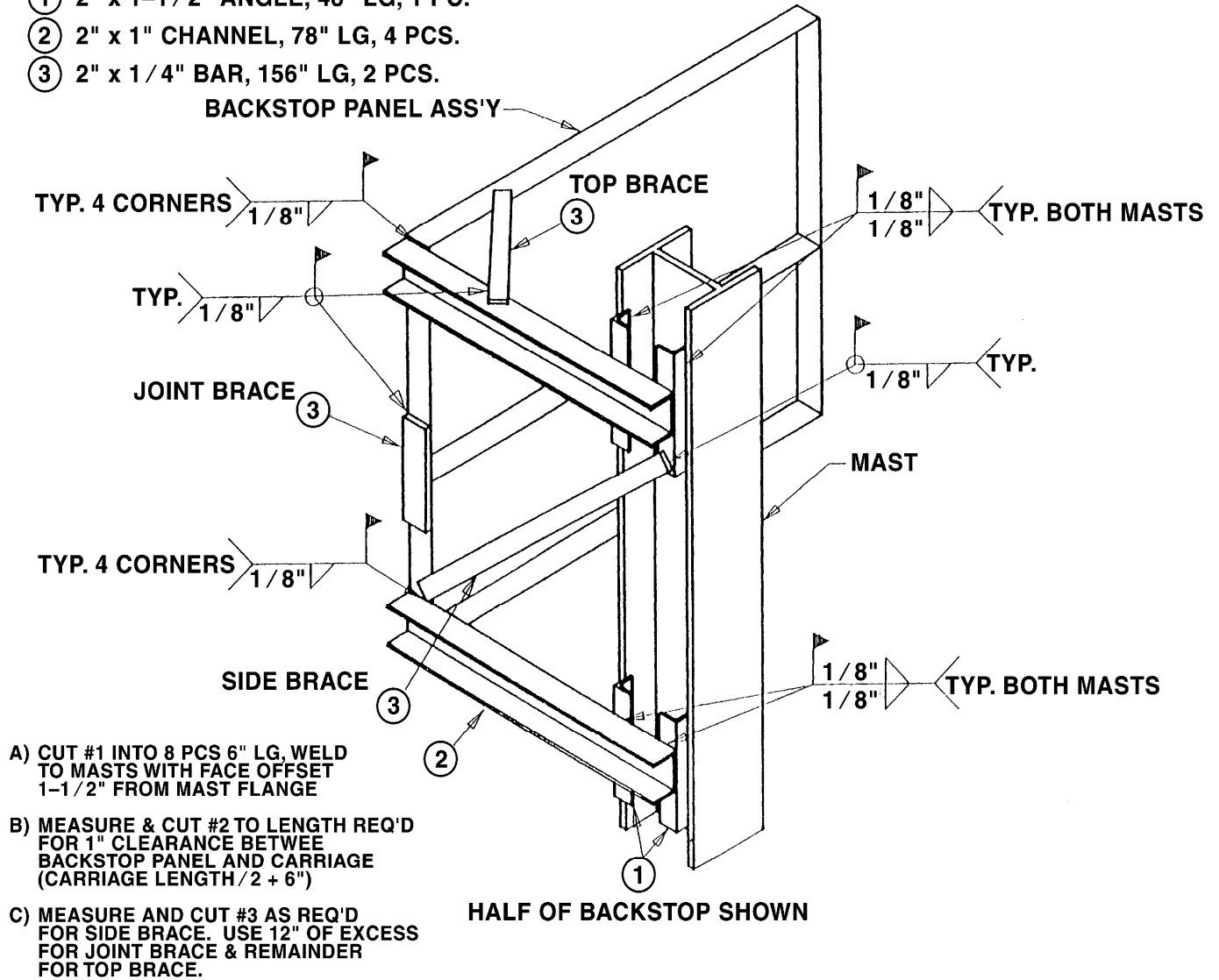

Figure 37 Backstop Panel Kit (when required)

OPERATING INSTRUCTIONS



DANGER!

To avoid personal injury or death, do not operate this equipment with substandard, defective, or missing parts or equipment supports. Contact a local FREIGHTLIFT service representative if a deficiency is found.



WARNING!

No riders! The FREIGHTLIFT is provided for the sole purpose of transporting goods between floor elevations. At no time should it be used to transport personnel.



WARNING!

All gates and/or doors of the FREIGHTLIFT are electrically interlocked and must be closed to permit operation the lift. Do not operate unit with doors open or with the interlocks or other safety devices “defeated” (bypassed)! Serious injury or death could result.



WARNING!

Never operate the lift by “manualling” the electrical controls (using the contactors located inside the control panel). All safety devices are bypassed in this mode of operation and lift damage or severe personal injury could occur.

NOTE: In order for the lift to operate:

- All gates/doors guarding the lift must be closed.
- Loads cannot hang over the edge or sides of the carriage.
- The load must be within the specified load capacity of the lift.
- All electrical safeties, sensors, and switches must be in their “closed” condition

UP

1. When an UP button on a push button station is pressed & released, the control (secondary) circuit to the motor starter (motor contactor) is completed. The coil of the motor starter magnetically closes the high (primary) voltage contacts completing the power circuit to the motor.

NOTE: Per ASME B20.1, operator pushbutton stations must be located such that they can not be activated while standing on the carriage

OPERATING INSTRUCTIONS

2. The motor turns the gears in the reducer, which in turn rotates the drive shaft. The sprockets on the shaft also turn resulting in the raising or lowering of the lifting chains (because the motor starter is reversible, the direction of travel can be alternated). The lifting chains are fastened to the wheel blocks, which are in turn bolted to the carriage, thereby raising or lowering the carriage.
3. When the carriage arrives at the landing it has been called to, the level limit switch (one per level) is activated by the striking of a mechanical cam attached to the side of the carriage. When activated, this switch cuts the power to the motor circuit, the motor starter contacts drop out (open), the motor stops, and the motor brake is automatically applied thereby stopping and holding the carriage at that landing.
4. The over-travel limit switch is a safety device mounted directly above the uppermost level limit switch. The only time it should activate is if there is a failure of the uppermost level limit switch. Again, the over-travel switch is activated by the striking of a mechanical cam attached to the side of the carriage. When activated, it cuts the power to the motor circuit.
NOTE: Always find out why the over-travel switch is activated and be sure to correct the problem before making the lift operational again.
5. The lift is supplied with an Electrical Current Sensor (ECS) with Trip Relay, so that excessive current draw due to carriage overloading or jammed carriage condition will cause the ECS to quickly cut off electrical power to the gear motor and prevent structural damage to the lift.
NOTE: Only a qualified technician should be allowed to reset the ECS to regain power to the lift gear motor.
NOTE: Always find out why the ECS cuts off power to the motor and be sure to correct the problem (load jam, over-load, etc.) before making the lift operational again.
6. If any of the lifting chains or drive chains should go slack or break during operation, the corresponding slack chain sensor will activate and cut off the electrical power to the motor and automatically apply the motor brake.
NOTE: Always find out why the slack chain sensors are activated, be sure they are set according to the procedures set forth herein, and be sure to correct the problem (carriage interference, etc.) before making the lift operational again.
NOTE: The locking cams mounted to the carriage will be engaged only if the chain breaks.



CAUTION!

Do not run operate the lift until all limit switches and sensing switches have been confirmed to be installed & adjusted correctly! Failure to do so could result in personal injury and/or permanent equipment damage.

OPERATING INSTRUCTIONS

DOWN

1. When a DOWN button on a push button station is pressed & released, the control (secondary) circuit to the motor starter (motor contactor) is completed. The coil of the motor starter magnetically closes the high (primary) voltage contacts completing the power circuit to the motor causing the reversing motor starter to engage and start the motor.
2. When the carriage arrives at the landing it has been called to, the level limit switch is activated by the striking of a mechanical cam attached to the side of the carriage. When activated, this switch cuts the power to the motor circuit, the motor starter contacts drop out (open), the motor stops, and the motor brake is automatically applied thereby stopping and holding the carriage at that landing.
3. A counterweight sensing switch has been provided to sense whether the counterweights attempt to be pulled out the top of their guide tubes in the event that: 1) the carriage is interfered with during its downward travel and physically stops downward movement prior to reaching the landing it was called to, and 2) the slack chain sensing switch(es) do not cut off power to the motor when this occurs. When activated, the counterweight sensing switch cuts off electrical power to the motor, and the motor brake automatically applies and holds the carriage at that landing.

NOTE: Always find out why the counterweight sensor(s) are activated, and be sure to correct the problem (carriage interference, etc.) before making the lift operational again.

EMERGENCY STOP

Press the red emergency stop button to stop all vertical movement of the FREIGHTLIFT at any time for any reason.

1. The emergency stop button will interrupt all electrical control functions when it is activated. Movement of the carriage will cease, regardless of its direction.
2. After the emergency stop button has been reset (twist), any level button may be pressed to continue travel.

NOTE: Always find out why the E-Stop button may have been pressed, and be sure to correct the problem (malfunction, interference, etc.) before making the lift operational again.

OPERATING INSTRUCTIONS

PREVENTING DAMAGE TO THE LIFT

1. Exceeding the Capacity of the Lift

The load capacity rating is stamped on a metal serial number plate attached to the lift. This figure is a net capacity rating for a lift furnished with the standard platform. The Electrical Current Sensor (ECS) has been set to raise the weight, plus a small amount for overload. Where conveyors, guarding, fixtures, etc, are installed on the lift after leaving the plant, deduct the weight of these from the load rating to obtain the net capacity. Loading the lift beyond its rated capacity is unsafe, will shorten the operational life of the lift, and will void its warranty.

2. Fork Truck Traffic

The end user is responsible for preventing damage to the lift carriage and structure by fork truck traffic, and fork truck loading & unloading (where applicable) by establishing and enforcing safe and effective loading procedures, and by installing appropriately sized barriers around the lift to minimize the likelihood of damage by fork truck impact (i.e. pipe bollards, steel barriers, fencing, etc.). Operating the lift with a bent or damaged carriage or guide beams is unsafe, will shorten the operational life of the lift, and will void its warranty.

3. Jammed Loads

Permanent lift damage can result when loads that are placed on the lift are allowed to hang over one or more edges of the carriage, and the carriage then sent to upper level landings past obstructions/features which could potentially jam the overhanging load. These features include shaft door openings, protruding landings, building joists/beams, backstop panels, ductwork, pipe, etc.. Care should be taken to eliminate jams by:

- a. Securing wheeled loads (pallet jacks, carts, racks, etc.) by braking or chocking the wheels to prevent the load from “walking” towards & over the edge of the carriage during lift travel.
- b. Inspecting the loads placed on the carriage to make they are well within the perimeter of the carriage before sending the load to another level .
- c. Making sure that all snap chains (or drop bars – in some cases) are secured across all loading/unloading sides prior to sending the load to an upper level.
- d. Placing permanent visual aids on the carriage deck surface for fork truck operators to know where to place loads within the perimeter of the carriage.

WHEN A CARRIAGE JAM OCCURS:

A jammed carriage may have damaged or broken the lifting chains or other critical components that are supporting the carriage.

- A. DO NOT attempt to free the jam by resetting the Electrical Current Sensor (ECS) relay in the control panel and running the lift further up or down.

OPERATING INSTRUCTIONS

- B. DO NOT walk out onto the carriage or attempt to physically free the jam until the carriage has been safely supported from beneath per instructions given in the “Lift Blocking” section of this manual.
- C. DO Call Autoquip (**888-811-9876**) to provide assistance in discovering the source & acceptable remedy for the carriage jam.
- D. DO call an authorized Autoquip dealer or representative to conduct a comprehensive inspection of the lift for structural and component damage before placing it back into service.



WARNING!

Close all gates when not in use! Never leave the FREIGHTLIFT unattended with the gates left open!

ROUTINE MAINTENANCE



DANGER!

To avoid personal injury or death, all maintenance procedures described in this section should only be performed by qualified service personnel.



DANGER!

To avoid personal injury or death, do not operate this equipment with substandard, defective, or missing parts. Contact a local FREIGHTLIFT service representative if a deficiency is found.



WARNING!

To avoid serious injury or death, **GUARDS, INTERLOCKS, and SAFETY DEVICES** must be restored to correct operation when installing parts or making repairs.

INSPECTION & MAINTENANCE SCHEDULE

The following inspection & maintenance schedule is based on an average annual usage of approximately 5,000 hours per year. Special applications such as high cycle, extreme temperatures, outdoor or wash-down applications, corrosive environments, and contaminated environments will require more frequent maintenance – and possibly different lubricants. Special ordered lift features may also require maintenance and are not included in the following schedules.

If you have any questions or problems, please feel free to contact you local service representative or the Autoquip Service Department for assistance (888-811-9876).

Every Month (300-400 hours of operation):

1. Check all components for signs of noise, vibration, erratic movement, and any other abnormal behavior.
2. Check overall condition of unit (i.e. bends, breaks, loose or missing bolts, etc.).
3. Look for any unusual rub marks on the guides, wall, platform carriage, masts, etc, which might indicate misalignment of the components due to overloading, misuse, or something out of tolerance.
4. Using a long handled broom or other implement, remove any debris from under the platform carriage or in the enclosed area.

ROUTINE MAINTENANCE



DANGER!

To avoid personal injury or death, before performing any static inspections, make sure the platform carriage is fully lowered and the power has been disconnected at the safety disconnect switch. Also, put signs at all gates, doors, controls, etc. indicating that the system is out of service for maintenance per OSHA Lock-Out, Tag-Out procedures.

Inspection List – Every 3 Months (1,000-1,200 hours of operation):

1. Coat drive & lifting chains with oil; inspect for wear, rust, and bent or binding links
2. Inspect carriage guide rollers for wear, binding, or other indication of non-rotation
3. Inspect all gate/door interlocks and status switches for proper operation
4. Inspect all gates/doors for wear or damage

Inspection List – Every 6 Months (2,000-2,500 hours of operation):

1. Pillow block bearings on the drive shaft should be greased; tighten all set screws
2. Inspect all chain sprockets for wear or damage; tighten set screws. Center lifting chains in counterweight tube, and center sprockets on the lifting chains.
3. Inspect chain tensioners and slack chain sensing switches for proper operation; adjust as required per procedure in the “General Maintenance” section.
4. Check that the platform carriage is actuating the limit switches correctly. Make sure that the platform carriage is lined up with the upper floor(s). Adjust limit switch arms, if required, per procedure in the “Installation” section.
5. Thoroughly inspect all Locking Cam assemblies, immediately replace any components which exhibit excessive wear, including but not limited to:
 - a. Locking Cam – any tooth edge which feels rounded or flattened in any way
NOTE: Locking cams are a critical component in the free-fall arrest safety system and become less effective after multiple engagements. Wheel guides / locking cams should be replaced after being engaged under full or partial load more than twice.
 - b. Locking Cam Spring – any broken, rusted, bent, or damaged springs or spring mounting bolts
 - c. Locking Cam Back-up Bar – a bent bar, or any damaged or missing mounting bolts, or bolts which are not Grade 8
 - d. Chain or Cable Adaptors (the “Yoke” transition piece between the chain and the locking cam) – a holding pin missing retaining/cotter pins on either end, any damaged or slightly bent retaining pin, or any sign of wear or “egging” of the pin holes in the adaptor piece
 - e. Chain Master Link or Repair Link – any damaged, slightly bent, or missing link pins or pin retaining clips/cotter pins, or any damaged link plate, or any chain component that does not appear to be made of similar workmanship, size, or quality as the rest of the lifting chain.

ROUTINE MAINTENANCE

Inspection List – Every 12 Months (4,000-5,000 hours of operation):

1. Conduct a full inspection of the unit by using the comprehensive Inspection Checklist found in the **Appendix** of this manual.
2. Check the gear oil level in the gear reducer. Gear oil should be flush with the bottom threads of the appropriate check plug. The fill and breather holes will be the top hole on one side and the fluid check hole will be a plug about half way up on the gear reducer. Use an ISO 220 grade EP gear oil for a temperature range of +104 degrees F to +32 degrees F. Use ISO 150 grade EP gear oil for a temperature range of +77 degrees F to +5 degrees F.

Inspection List – Every 24 Months (8,000-10,000 hours of operation):

1. Change gear oil in the gear reducer of the drive. Use an ISO 220 grade EP gear oil for a temperature range of +104 degrees F to +32 degrees F. Use ISO 150 grade EP gear oil for a temperature range of +77 degrees F to +5 degrees F.

GENERAL MAINTENANCE



DANGER!

To avoid personal injury or death, the procedures described in this section should only be performed by qualified service personnel.



WARNING!

Never operate the lift by “manualling” the electrical controls (using the contactors located inside the control panel). All safety devices are bypassed in this mode of operation and lift damage or severe personal injury could occur.

ADJUSTING LEVEL & OVER-TRAVEL LIMIT SWITCHES

To ensure proper setting and performance of all Level Limit Switches and Over-Travel Limit Switch, follow the procedure set forth in **Paragraph J** of the “**Installation**” section.

NOTE: Should you have any questions or need assistance please call Autoquip Customer Service (888-811-9876).

ADJUSTING SLACK CHAIN SENSING SWITCHES



WARNING!

Slack chains require factory help! Do not attempt to repair slack chain conditions alone! Always contact the local representative or call the *Autoquip* Service Department at 888-811-9876.

To ensure proper setting and performance of all Drive Chain & Lifting Chain Sensing Switches, follow the procedure set forth in **Paragraph K** of the “**Installation**” section.

GENERAL MAINTENANCE

ADJUSTING COUNTERWEIGHT SENSING SWITCH

To ensure proper setting and performance of the Counterweight Sensing Switch, follow the procedure set forth in **Paragraph L** of the “**Installation**” section.

NOTE: Should you have any questions or need assistance please call Autoquip Customer Service (888-811-9876).

ADJUSTING THE ECS CURRENT SETTING



DANGER!

Secure platform and chains! Do not remove or disconnect the motor or brake unless the platform and chains have been secured. Serious injury or death may result. See “Blocking Instructions” section.

To ensure proper setting and performance of the Counterweight Sensing Switch, follow the procedure set forth in **Paragraph Q** of the “**Installation**” section.

NOTE: Should you have any questions or need assistance please call Autoquip Customer Service (888-811-9876).



WARNING!

To avoid serious injury or death, GUARDS, INTERLOCKS, and SAFETY DEVICES must be restored to correct operation when installing parts or making repairs.

REPLACEMENT PARTS LIST

Specific part numbers vary from job to job, depending on the model and options chosen for the application. Call the *Autoquip* Service Department at (405) 282-5200 or 1-888-811-9876 with the serial number of the specific FREIGHTLIFT equipment to order the appropriate parts.

62822901	TOP GUIDE, LEFT HAND
62822911	TOP GUIDE, RIGHT HAND
62822920	LOWER GUIDE, LEFT HAND
62822930	LOWER GUIDE, RIGHT HAND
35100910	COUNTERWEIGHT LIMIT SWITCH
35100960	SLACK CHAIN SENSING SWITCH KIT

TROUBLESHOOTING ANALYSIS



DANGER!

To avoid personal injury, **NEVER** go under the lift platform until it is securely blocked (See "Blocking Instructions" section) and the load is removed.

Troubleshooting and maintenance on the lift should only be performed by qualified service technicians!!

Never walk out onto a jammed carriage until it has been properly blocked or secured from further movement (See "Blocking Instructions" section)

Maintenance personnel should always speak to the operator(s) of the lift prior to troubleshooting – to gain insight into the potential cause(s) of the problem.

PROBLEM	POSSIBLE CAUSE AND SOLUTION
<p>Freightlift will not raise (motor <u>not</u> running or "humming").</p> <p>WARNING! The lifting chains may be disconnected and slack chain sensing switches missing or malfunctioning. Check while standing near (but NOT on) the lift carriage and correct as necessary – once carriage has been blocked in place.</p> <p>WARNING! a safety device may have been activated – if you are not familiar with how safety devices interact with the operation of the lift, you must find someone who does. Or, call Autoquip Customer Service at 888-811-9876.</p>	<ul style="list-style-type: none"> • A slack chain sensing switch is activated due to a slack or broken chain condition, or the sensing switch is malfunctioning or is out of tolerance. Check and/or re-establish chain tension, or check & repair or adjust sensing switch(es) as required per "Installation" section. • The Electric Current Sensor (ECS) has tripped due to an excessive or jammed load on the carriage. Reduce load to within rated capacity, or follow procedure to free the jammed load (See "Installation" section for procedure) • The counterweight sensing switch, over-travel switch, or other safety status switches/sensors may have been tripped. Investigate cause and eliminate the condition which has caused them to trip. • The level limit switch tripped or is malfunctioning, preventing the "UP" command. Check with the lift at a lower level on stops. • The emergency stop button may be depressed or jammed. Check all pushbutton stations. Repair / replace. • The main disconnect switch / distribution panel circuit breaker is tripped or a fuse is blown. Check and reset or replace as necessary. • A door with status switch is open, or switch or interlock is malfunctioning or is out of tolerance. Close door, or check and repair or adjust as required per gate manual (shipped separately – when gates supplied by Autoquip) • The push button / circuit is malfunctioning. Check components and circuit. Repair or replace. • The motor starter overloads (MSO) have tripped. Check and reset. If it trips again, check for cause in the motor circuit. • The control transformer fuse is blown. Check and replace.

TROUBLESHOOTING ANALYSIS

PROBLEM	POSSIBLE CAUSE AND SOLUTION
<p>Freightlift will not raise (motor <u>is</u> running or “humming”).</p> <p>WARNING! a safety device may have been activated – if you are not familiar with how safety devices interact with the operation of the lift, you must find someone who does. Or, call Autoquip Customer Service at 888-811-9876.</p>	<ul style="list-style-type: none"> • WARNING! The lifting chains may be disconnected or broken and slack chain sensing switches missing or malfunctioning. Check while standing near (but NOT on) the lift carriage and correct as necessary – once carriage has been blocked in place. • The load may exceed the rated capacity of the lift. Remove any excess load. • Rotation on the 3-phase motor may be reversed. Reverse any two motor electrical leads. • The 3-phase motor may be single-phasing (humming). Check wiring, fuses, etc. • The voltage at the motor terminals may be too low to run the motor with the existing load. Check by measuring the voltage at the motor terminals (or as near as possible) while the motor is running under load. Inadequate or incorrect wiring can starve the motor when the source voltage is ample. Correct as necessary. • The motor brake may be seized if the motor is humming, blowing fuses, or overloads. Remove the motor and check to see if the brake is working correctly.
<p>Motor labors or heats excessively.</p>	<ul style="list-style-type: none"> • The voltage may be low. Check at the motor terminals while the motor is running under load. Inadequate wiring can starve the motor even when the source voltage is ample. • The wiring may be incorrect. Be sure one leg of the motor line is not connected to the ground prong. This can happen particularly on 3-phase units using twist-lock plugs. • The gear reducer may be binding from oil starvation. This can cause high internal heat. The gear reducer can be irreparably damaged by oil starvation and may have to be replaced!
<p>Unit operates in a “spongy” or jerky fashion.</p>	<ul style="list-style-type: none"> • The chain sprockets may be binding. Check and repair • The chain may be off of a sprocket. Check and repair. • The platform carriage may be binding in the guide ways. Check and repair.

TROUBLESHOOTING ANALYSIS

PROBLEM	POSSIBLE CAUSE AND SOLUTION
<p>Freightlift will not lower (electrically).</p> <p>WARNING! The lifting chains may be disconnected and slack chain sensing switches missing or malfunctioning. Check while standing near (but NOT on) the lift carriage and correct as necessary – once carriage has been blocked in place.</p> <p>WARNING! a safety device may have been activated – if you are not familiar with how safety devices interact with the operation of the lift, you must find someone who does. Or, call Autoquip Customer Service at 888-811-9876.</p>	<ul style="list-style-type: none"> • A slack chain sensing switch is activated due to a slack or broken chain condition, or the sensing switch is malfunctioning or is out of tolerance. Check and/or re-establish chain tension, or check & repair or adjust sensing switch(es) as required per “Installation” section. • The Electric Current Sensor (ECS) has tripped due to an excessive or jammed load on the carriage. Reduce load to within rated capacity, or follow procedure to free the jammed load (See “Installation” section for procedure) • The counterweight sensing switch, over-travel switch, or other safety status switches/sensors may have been tripped. Investigate cause and eliminate the condition which has caused them to trip. • The level limit switch tripped or is malfunctioning, preventing the “UP” command. Check with the lift at a lower level on stops. • The emergency stop button may be depressed or jammed. Check all pushbutton stations. Repair as necessary. • The main disconnect switch / distribution panel circuit breaker is tripped or a fuse is blown. Check and reset or replace as necessary. • A door with status switch is open, or switch or interlock is malfunctioning or is out of tolerance. Close door, or check and repair or adjust as required. • The push button / circuit is malfunctioning. Check components and circuit. Repair or replace. • The motor starter overloads (MSO) have tripped. Check and reset. If it trips again, check for cause in the motor circuit. • The control transformer fuse is blown. Check and replace.
<p>The Freightlift lowers too slowly with a load.</p>	<ul style="list-style-type: none"> • The motor brake may be malfunctioning. Check and repair. (See “Lift Blocking” section for safe removal of brake)
<p>Freightlift raises, then lowers back slowly.</p>	<ul style="list-style-type: none"> • The motor brake is not locking the motor drive. The brake needs to be adjusted or replaced. Check for brake material in the brake cover housing. (See “Lift Blocking” section for safe removal of brake)
<p>The Freightlift does not raise completely to the upper level (press “emergency stop” button to stop motor.)</p>	<ul style="list-style-type: none"> • Check the upper limit switch setting to see if the setting is correct. • There is some sort of interference with the platform carriage. Check and correct. • The load exceeds the capacity of the unit. Lower the unit, unload, and try again.

GLOSSARY OF TERMS

TERM	DEFINITION
Anchors	Bolts used to fix masts to the floor
ATF	Automatic transmission fluid
Back frame	The vertical portion of the carriage on the cantilever Freightlift
Cantilever	A style of Freightlift where the carriage rides along two masts that are mounted on the same side of the carriage. This style of lift will accommodate all three loading patterns.
Capacity	The maximum load the Freightlift will lift
Carriage	The entire assembly that travels on the mast and carries the load
Chain	
Controls	Any electrical device used in the operation of a Freightlift, which normally includes push button stations, control boxes, limit switches, interlocks, etc.
Cycle	The lift is considered to have operated one cycle any time the motor starts.
Drive	Gear motor drive located at top of lift mounted to the drive base tube
ECS	Electrical Current Sensor – located in the motor control panel & designed to keep the current overloads from kicking out as a result of high initial amp draw at motor start
Enclosure	A structure surrounding the Freightlift to prevent anything from interfering with normal operation of the lift, and to protect personnel. Typically eight-foot high panels made of expanded metal that will prevent a two-inch diameter ball from passing through. This is a requirement of the conveyor code (ANSI-B20.1)
Gate	A device that opens and closes to allow access to the carriage for loading and unloading. Normally a swing, sliding, or vertical acting device constructed of similar expanded metal as the enclosure.
Interlock	An electrical mechanical system for doors or gates to prevent operation of the lift if all the gates are not closed or if the lift platform is not level.
Limit Switch	An electrical device by which the movement of the Freightlift may be controlled within predetermined limits.
Load height	The maximum height of the material a carriage can accommodate.
Load pattern	A method to describe how a Freightlift will be loaded at different levels.
Locking Cam	Free-fall arrest safety device attached to the lifting chain to sense slack chain conditions and automatically & mechanically lock / jam carriage into the guide beams
Masts	The vertical members between which the carriage is guided throughout its vertical travel.
Mechanical	Actuated by mechanical means – i.e. through gear motor drive to chain & sprockets

GLOSSARY OF TERMS

TERM	DEFINITION
Motor starter	A motor controller component for accelerating a motor from rest to normal speed.
Non-operating end	The side(s) of the platform not used for loading/unloading. Handrails with midrails and kick plates are supplied as minimum safety protection.
Operating end	The side(s) of the platform used for loading/unloading. A safety chain is supplied as minimum safety protection.
Over Travel Sensors	Sensors located above uppermost level limit switch to sense when carriage travels above uppermost limit and send signal to turn off motor
Platform	The horizontal surface of the carriage where the load is placed.
Roll off panel	A structure used on the upper levels to prevent personnel/products from falling off the platform when loading.
Secured	Held in place; physically restrained from experiencing any downward movement
Slack Chain Sensors	Sensors located on drive base, designed to sense when tension in any lifting chain is lost and send signal to turn off motor
Snap chain	A length of chain with a clasp on the end to close off the operating end of a carriage.
Straddle	A style of Freightlift in which the carriage rides between two masts that are mounted on opposite sides of the carriage. This style will accommodate both "C" and "Z" loading patterns.
VRC	Vertical reciprocating conveyor
Vertical travel	The distance from the lowest point of infeed or discharge to the highest point of infeed or discharge

APPENDIX

INSPECTION CHECKLIST

This checklist is intended to assist qualified maintenance and inspection personnel to inspect Freightlift installations for proper installation and maintenance concerns.

- The lift should be run several times, and carriage sent to each loading level, in unloaded condition for static inspection, and loaded condition during the dynamic inspection. In this way, a wider variety of issues will present themselves as actual operating conditions are duplicated as closely as possible.
- Inspection personnel should have at their disposal the tools and aids necessary to access and observe all the components mentioned in the checklist, and be trained to safely make these observations.
- If deficiencies are identified, they must be fixed and/or reported to the owner.

Y N

A. GENERAL

- | | | |
|--|--------------------------|--------------------------|
| 1 Is the Lift being used as it was sold to be used?
(load capacity, edge/wheel loading, load frequency, no riders, etc.) | <input type="checkbox"/> | <input type="checkbox"/> |
| 2 Do you suspect there have been unauthorized modifications of any kind made to the Lift since installation ? (pp.5,18) Describe | <input type="checkbox"/> | <input type="checkbox"/> |
| 3 Any unusual noises being generated as it is operated?
(rubbing, scraping, humming, squealing, popping, etc) Source? | <input type="checkbox"/> | <input type="checkbox"/> |
| 4 Is the Lift operating path/pit free of debris & obstructions? | <input type="checkbox"/> | <input type="checkbox"/> |

B. STRUCTURAL

- | | | |
|---|--------------------------|--------------------------|
| 1 Lift carriage deck bent / damaged / modified in any way?
(possible overloading or jamming of loads between floors) | <input type="checkbox"/> | <input type="checkbox"/> |
| 2 Carriage uprights bent / damaged / modified in any way?
(possible falling and/or wedging of carriage inside guide beams) | <input type="checkbox"/> | <input type="checkbox"/> |
| 3 Carriage overhead channel bent / damaged / modified?
(possible over-travel of lift where carriage contacts drive base) | <input type="checkbox"/> | <input type="checkbox"/> |
| 4 Lift drive base bent/damaged/modified in any way ?
(possibly too much motor torque - ECS not set correctly) | <input type="checkbox"/> | <input type="checkbox"/> |
| 5 Guide beams braced/secured as recommended? (pp.39-43)
(anchored to resist rated loads, no movement during carriage travel) | <input type="checkbox"/> | <input type="checkbox"/> |
| 6 Guide beams plumbed and straight as recommended? (pp.40,44)
(1/8" over any 10 ft length, not to exceed 3/8" overall) | <input type="checkbox"/> | <input type="checkbox"/> |
| 7 Distance between guide beams is consistent throughout travel?
(also referred to as mast setting dimension) | <input type="checkbox"/> | <input type="checkbox"/> |
| 8 Guide beam flanges/guide angles show signs of excessive wear?
(look for metal shavings, snap rings, etc. on ground near mast foot) | <input type="checkbox"/> | <input type="checkbox"/> |
| 9 Unauthorized structural members added in field – especially
to the guide beams and drive base? (pp. 18,23,47) | <input type="checkbox"/> | <input type="checkbox"/> |
| 10 Any broken or cracked bolts or welds otherwise observed? | <input type="checkbox"/> | <input type="checkbox"/> |
| 11 Any other wear marks on any component of the lift? (p.82) Describe | <input type="checkbox"/> | <input type="checkbox"/> |

APPENDIX

C. MECHANICAL

- | | Y | N |
|--|--------------------------|--------------------------|
| 1 Lifting chain system is installed properly (pp. 24, 52-58, 83) | | |
| a. lifting chain has correctly sized & installed master links?
(keepers in place, also look for excessive number of master links) | <input type="checkbox"/> | <input type="checkbox"/> |
| b. chain adaptor/pins/keepers are factory-supplied & undamaged?
(look for egging, rounding or extrusion of metal at edge of pin holes) | <input type="checkbox"/> | <input type="checkbox"/> |
| c. lifting chain is aligned with, and properly engaging, sprockets?
(look for cracked/missing teeth, excessive wear, binding on sprocket) | <input type="checkbox"/> | <input type="checkbox"/> |
| d. all lifting chains are of equal length - and carriage hanging level? | <input type="checkbox"/> | <input type="checkbox"/> |
| e. chain counterweights installed & undamaged?
(look for sprocket marks, pin damage, etc.) | <input type="checkbox"/> | <input type="checkbox"/> |
| 2 Guide wheels – turn smoothly & square to beams? (pp.36-38,83) | <input type="checkbox"/> | <input type="checkbox"/> |
| 3 Platform tensioners – mounted & functioning properly (p.39,42) | <input type="checkbox"/> | <input type="checkbox"/> |
| 4 Is the motor/gearbox overheating? (p.84)
(check fluid level and color, as well as voltage at the panel) | <input type="checkbox"/> | <input type="checkbox"/> |
| 5 All field-bolting – grade 8 bolts, tightened per spec (pp.24) | | |
| a. Carriage to uprights? (99 ft-lbs) (p.34) | <input type="checkbox"/> | <input type="checkbox"/> |
| b. Uprights to wheel guide blocks? (99 ft-lbs) (p.39,42) | <input type="checkbox"/> | <input type="checkbox"/> |
| c. Uprights to overhead channels? (26 ft-lbs) (p.34) | <input type="checkbox"/> | <input type="checkbox"/> |
| d. Drive base to guide beams? (99 ft-lbs) (pp. 44,45) | <input type="checkbox"/> | <input type="checkbox"/> |

D. ELECTRICAL

- | | | |
|--|--------------------------|--------------------------|
| 1 Operator P/B stations undamaged & functional? (pp.70,71)
(call/send from all levels, all E-stops, key switches, etc.) | <input type="checkbox"/> | <input type="checkbox"/> |
| 2 Operator P/B stations at least 6 ft. from Lift carriage? (pp.25,77) | <input type="checkbox"/> | <input type="checkbox"/> |
| 3 Main disconnect & motor control panels unaltered? (pp.24,25, NEC) | <input type="checkbox"/> | <input type="checkbox"/> |
| 4 Disconnect & motor control panel visible from Lift?(pp.24,25, NEC) | <input type="checkbox"/> | <input type="checkbox"/> |
| 5 Any evidence that safeties are being bypassed inside the panel? | <input type="checkbox"/> | <input type="checkbox"/> |
| 6 Does the location of the disconnect & control panels meet NEC ? | <input type="checkbox"/> | <input type="checkbox"/> |
| 7 Any cut/damaged/ frayed electrical conduit or wires? (p.5) | <input type="checkbox"/> | <input type="checkbox"/> |
| 8 Other electrical connections meet NEC? | <input type="checkbox"/> | <input type="checkbox"/> |

APPENDIX

E. PERSONNEL & EQUIPMENT SAFETIES	Y	N
1 Have all operators been formally trained to use this lift? (and do they have a copy of the manual)	<input type="checkbox"/>	<input type="checkbox"/>
2 Are gates & enclosures installed around lift per ASME B20.1? (p.25) (are they secure, stable, able to keep out personnel?)	<input type="checkbox"/>	<input type="checkbox"/>
3 Do all Gate interlocks function properly? (pp.77,83) (gate must NOT open if carriage is NOT at that level)	<input type="checkbox"/>	<input type="checkbox"/>
4 Are all Safety Labels on the carriage? (pp. 15-17)	<input type="checkbox"/>	<input type="checkbox"/>
5 All Safety Labels at each landing per VRC Application Guidelines?	<input type="checkbox"/>	<input type="checkbox"/>
6 Lift should not operate with any safety features bypassed (pp.77,83)		
a. Will Lift operate with ANY gates/doors open? (gates/doors brought to nearly-closed / ajar condition)	<input type="checkbox"/>	<input type="checkbox"/>
b. Will Lift operate in a slack chain condition? (slack chain sensors must be set per factory specs – p.64-67)	<input type="checkbox"/>	<input type="checkbox"/>
c. Will Lift operate while Over-travel limit switch made? (p.59-61)	<input type="checkbox"/>	<input type="checkbox"/>
d. Will Lift operate while Counterweight limit switch made?(p.68,69)	<input type="checkbox"/>	<input type="checkbox"/>
7 Lift stops at a safe load transfer elevation at every level? (p.59-61) (whether traveling UP or DOWN past the level limit switches)	<input type="checkbox"/>	<input type="checkbox"/>
8 On-carriage rails, guards & snap chains in place? (p.25)	<input type="checkbox"/>	<input type="checkbox"/>
9 On-carriage rails, guards & snap chains at least 42" high? (p.25)	<input type="checkbox"/>	<input type="checkbox"/>
10 Are carriage back-stop panels across all elevated, non-operating sides of carriage – maximum 2" from edge of carriage? (p.72)	<input type="checkbox"/>	<input type="checkbox"/>
11 Platform locking cams are in good condition (p.83)		
a. Locking cam teeth are sharp, not rounded or flattened?	<input type="checkbox"/>	<input type="checkbox"/>
b. Locking cam springs are not rusted, bent, damaged, or broken?	<input type="checkbox"/>	<input type="checkbox"/>
c. Locking cam back-up bar not bent or missing bolts?	<input type="checkbox"/>	<input type="checkbox"/>
12 Motor brake stops & holds carriage at each loading level?	<input type="checkbox"/>	<input type="checkbox"/>
13 Do the door thresholds which protrude into shaft (or away from wall) have a beveled slope on underside to push away loads which may overhang the carriage as it travels up to that level (prevents jams)?	<input type="checkbox"/>	<input type="checkbox"/>
14 Is the Electrical Current Sensor (ECS) in the motor control panel set to lift the fully rated load, but trip when overloaded ? (pp.72,73)	<input type="checkbox"/>	<input type="checkbox"/>

LIMITED WARRANTY

The user is solely responsible for using this equipment in a safe manner and observing all of the safety guidelines provided in the Owner's Manual and on the warning labels provided with the lift. If you are unable to locate either the manual or the warning labels, please contact Autoquip (888-811-9876) or access www.autoquip.com for replacement downloads or information.

Autoquip Corporation expressly warrants that this product will be free from defects in material and workmanship under normal, intended use for a period of One (1) Year for all electrical, mechanical, and hydraulic components, parts or devices, and warrants the structure of the lift against breakage or failure for a period of Five (5) years. The warranty period begins from the date of shipment. When making a claim, immediately send your dealer or Autoquip notice of your claim. All claims must be received by Autoquip within the warranty time period. The maximum liability of Autoquip, under this Limited Warranty, is limited to the replacement of the equipment.

This warranty shall not apply to any Autoquip lift or parts of Autoquip lift that have been damaged or broken in transit/shipping, or due directly or indirectly to misuse, abuse, vehicle impact, negligence, faulty installation, fire, floods, acts of God, accidents, or that have been used in a manner contrary to the manufacturer's limitations or recommendations as stated in the manual, or that have been repaired, altered or modified in any manner outside of Autoquip Corp's manufacturing facility or which have not been expressly authorized by Autoquip.

Autoquip Corporation makes no warranty or representation with respect to the compliance of any equipment with state or local safety or product standard codes, and any failure to comply with such codes shall not be considered a defect of material or workmanship under this warranty. Autoquip Corporation shall not be liable for any direct or consequential damages resulting from such noncompliance.

Autoquip Corporation's obligation under this warranty is limited to the replacement or repair of defective components at its factory or another location at Autoquip Corp's discretion at no cost to the owner. This is owner's sole remedy. Replacement parts will be warranted for the remainder of the equipment warranty period or ninety (90) days, whichever is longer. Except as stated herein, Autoquip Corporation will not be liable for any loss, injury, or damage to persons or property, nor for direct, indirect, or consequential damage of any kind, resulting from failure or defective operation of said equipment. All parts used to replace defective material must be genuine Autoquip parts in order to be covered by this Limited Warranty.